



Scan for full manual

## VIA Connect<sup>2</sup> Quick Start Guide For Installer



This guide helps you install and configure your VIA Connect<sup>2</sup> for the first time.

Go to [www.kramerav.com/downloads/VIA\\_Connect<sup>2</sup>](http://www.kramerav.com/downloads/VIA_Connect2) to download the latest user manual and check if firmware upgrades are available.

### Step 1: Check what's in the box

- ✓ VIA Connect<sup>2</sup> Collaboration Device
- ✓ 1 VESA mounting bracket
- ✓ 1 Video toggle cable
- ✓ 1 Power supply (12V DC) with adapters for US, UK, and EU
- ✓ 1 VESA screw set
- ✓ 1 Quick start guide

### Step 2: Get to know your VIA Connect<sup>2</sup>

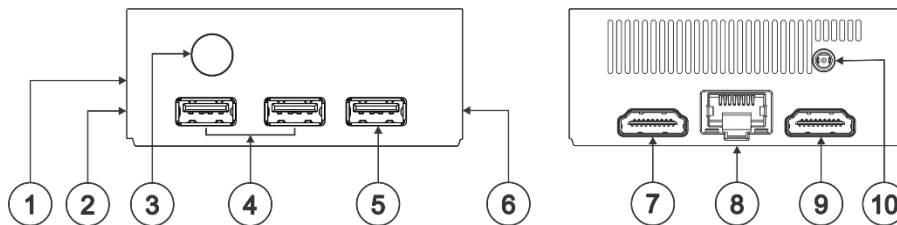

#	Feature	Function
1	Video Toggle Connector	Connect to video toggle cable for toggling between VIA input and HDMI™ input.
2	Micro SD Card Slot	Not in use.
3	Power Button with LED	Press to power ON or turn OFF the device.
4	USB 3.0 Connectors (x2)	Connect to USB devices, for example, a keyboard and a mouse.
5	USB 2.0 Connector	Connect to a USB device, for example, a keyboard or mouse.
6	Lock Opening	Connect to a security locking cable.
7	HDMI™ OUT Connector	Connect to an HDMI sink.
8	RJ-45 Connector	Connect to a LAN (default mode).
9	HDMI™ IN Connector	Connect to an HDMI source.
10	Power Connector	Connect to the 12V DC power supply.

### Step 3: Install VIA Connect<sup>2</sup>

Place VIA Connect<sup>2</sup> on a flat surface, or mount on a wall or the back of a display using the included VESA mounting bracket:

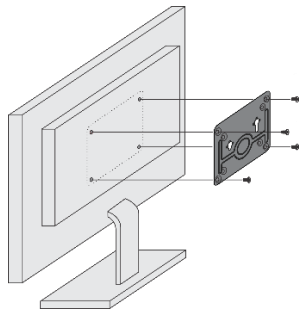

1. Attach the VESA mounting bracket to the back of the display with 4 screws.

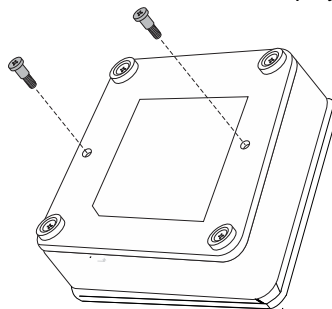

2. Fasten two screws to the bottom of VIA Connect<sup>2</sup>.

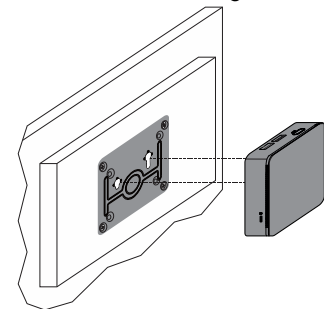

3. Insert the screws on the bottom of VIA Connect<sup>2</sup> into the slots on the mounting bracket.



## Step 4: Connect the inputs and outputs

Always switch OFF the power on each device before connecting it to your **VIA Connect<sup>2</sup>**. For best results, we recommend that you always use Kramer high-performance cables to connect AV equipment to **VIA Connect<sup>2</sup>**. Using third-party cables may cause damage!

1. Connect the keyboard and mouse.
2. Connect an HDMI display.
3. Connect to the LAN (default mode).
4. If required, connect a wired HDMI video source.



If you wish to use a Kramer active optical pluggable HDMI cable with your **VIA Connect<sup>2</sup>**, contact your local Kramer office to assist in purchasing the correct cable.

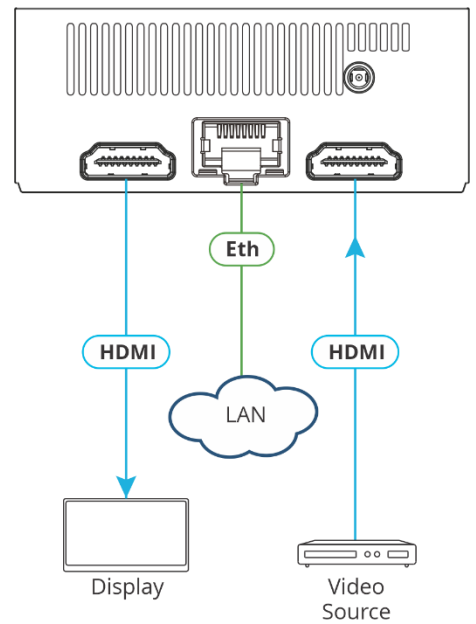
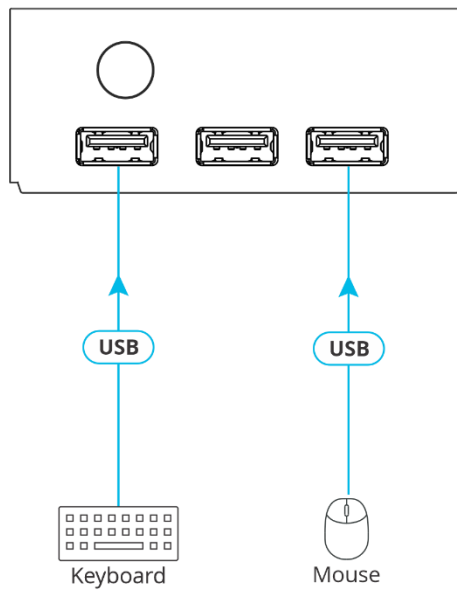

## Step 5: Connect the power

Connect the 12V DC power adapter to **VIA Connect<sup>2</sup>** and plug it into the mains electricity.



- Caution:** There are no operator serviceable parts inside the unit.
  - Warning:** Use only the Kramer Electronics power adapter that is provided with the unit.
  - Warning:** Disconnect the power and unplug the unit from the wall before installing.
- See [www.KramerAV.com](http://www.KramerAV.com) for updated safety information.

## Step 6: Configure VIA Connect<sup>2</sup>

A wizard guides you through configuration. If you choose to skip the wizard, follow these steps for configuration:

### General Settings Configuration

1. On the main display, click the VIA icon in the lower left corner. The VIA gateway dashboard appears.
2. Click **Settings**. The settings login window appears.
3. Enter the User Name (default = su) and Password (default = supass) and click **Login**. The VIA Settings window appears.

The VIA Settings tabs are:

- LAN Settings – Configure network parameters (default = DHCP)
  - System Controls – Define audio input and output sources, change display resolution, view system health indicators, and activate your unit.
  - Wi-Fi – Activate and configure the built-in Wi-Fi capability.
4. When you have finished configuring settings, click **Reboot** to apply all settings.

The screenshot shows the VIA Settings login window. It has a dark background with white text. At the top left is the VIA logo. Below it are two input fields: 'User Name:' and 'Password:'. At the bottom right are two buttons: 'Login' (in blue) and 'Cancel' (in white).

### Change to AP Wi-Fi Mode

Set up the built-in Wi-Fi module as a secondary Access Point (for guests).

1. On the Wifi tab, click the **Wifi Settings** switch. The switch turns green and additional Wi-Fi settings appear.
2. Click **AP Mode**, and enter a new name in the SSID field and a new password or use the default name and password.
3. Select a Wi-Fi channel for the Access Point.
4. Select **Enable Internet** (if the primary LAN network is connected to the Internet) OR **Activate Standalone Wifi** (to create an autonomous network without Internet access) and click **Apply**.

### Switch to Client Wi-Fi Mode

Attach your **VIA Connect<sup>2</sup>** as a client device to your main network:

1. On the Wifi tab, click the **Wifi Settings** switch. The switch turns green and additional Wi-Fi settings appear.
2. Click **Client Mode**, select an available network from the drop-down.
3. Enter the required password and click **Apply**.
4. Disconnect the LAN cable (if connected) before rebooting the device.



Scan for full manual

## VIA Connect<sup>2</sup> Quick Start Guide For User

This guide helps you participate in a meeting using VIA Connect<sup>2</sup>.

Go to [www.kramerav.com/downloads/VIA\\_Connect<sup>2</sup>](http://www.kramerav.com/downloads/VIA_Connect2) to download the latest user manual.



### Step 7: Connect your personal device to the proper network

Connect your personal device to the same Wi-Fi network to which the VIA Connect<sup>2</sup> in your meeting room is connected.

### Step 8: Run or download the Kramer VIA app

For Mac or PC:

1. Enter the Room Name of the VIA Connect<sup>2</sup> device into your computer's browser. The Welcome page of VIA Connect<sup>2</sup> appears.

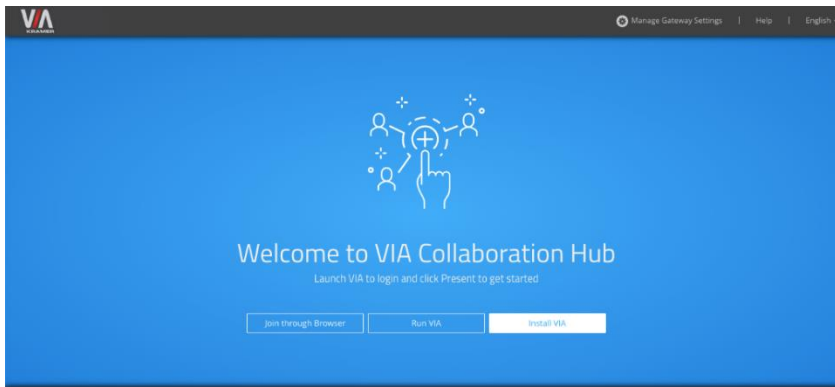

2. Click **Run VIA** to execute the **Kramer VIA** app without downloading it. (Intended for guests who are using VIA only temporarily.)  
OR  
Click **Install VIA** to download the **Kramer VIA** app onto your computer. (Intended for regular users of VIA.)  
OR  
Click **Join Through Browser** to use an online version of Kramer VIA. (Only when there is internet access.)

For iOS or Android devices:

- Download and install the free **Kramer VIA** app from Apple App Store or Google Play or scan the QR code above.

### Step 9: Join the meeting using Kramer VIA App

1. Open the Kramer VIA app and, on the Welcome to VIA window, click **Join** next to the name of the VIA device to which you want to connect. The Login window appears.
2. In the Nickname field, enter a name for your device. This name appears on the main display when you present content.
3. In the Room Code field, enter the 4-digit code as it appears on the main display (if enabled).
4. Click **Join**.  
You are logged into the VIA meeting.  
The VIA Dashboard (and taskbar icon for laptops) appears on your device screen.

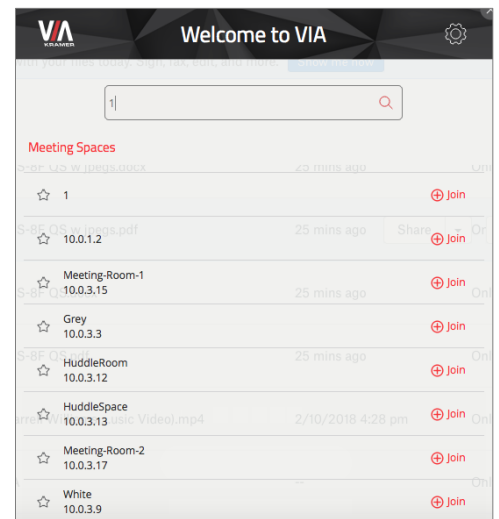

## Step 10: Using the VIA dashboard menu

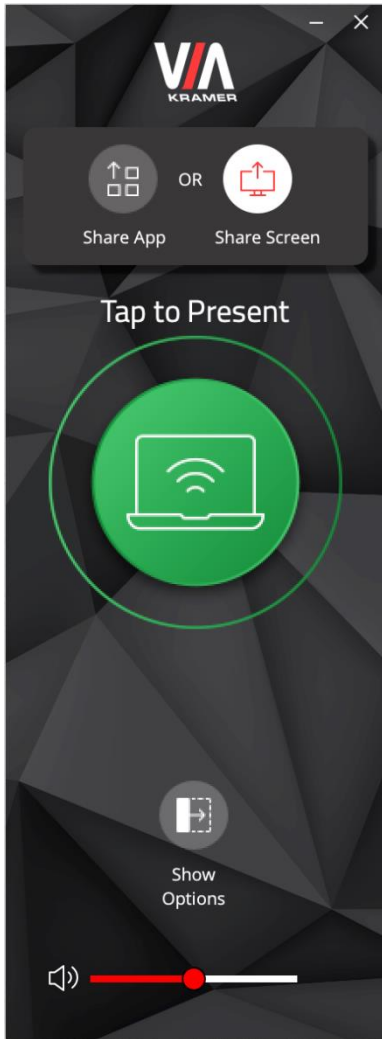

- Tap the green button to present your screen to the meeting participants on the main display.
- Tap **Show Options > Features** to access **VIA Connect<sup>2</sup>** features.
- Tap **Show Options > Participants** to see who else is connected.

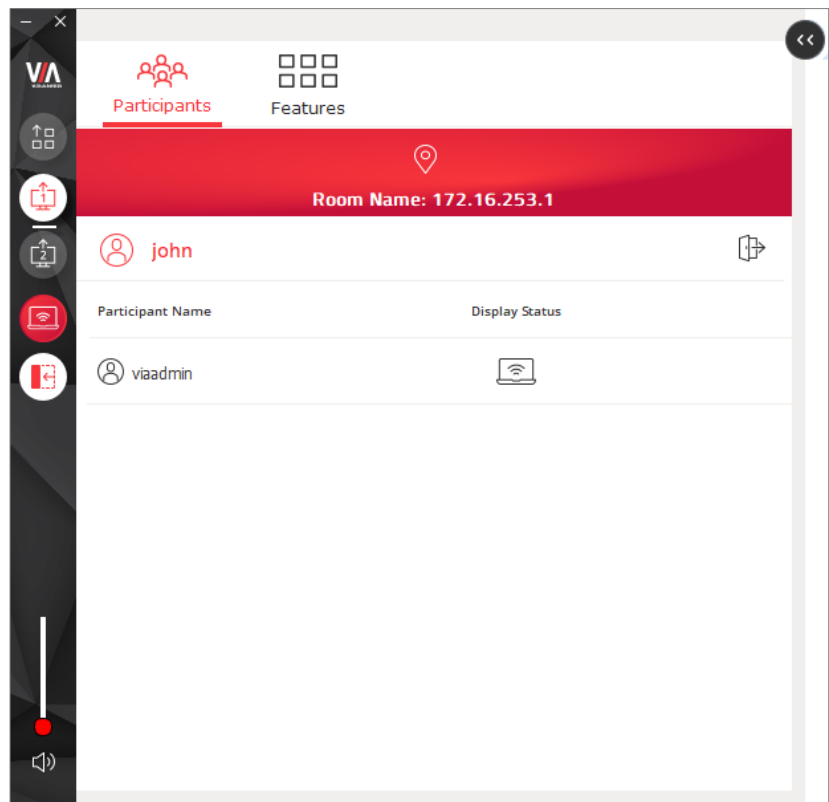

## Step 11: VIA Connect<sup>2</sup> Features

For a complete, updated list of available features go to: [www.true-collaboration.com/products.html#](http://www.true-collaboration.com/products.html#).



Wireless Connection



Powerful Content Security



Video Streaming



Mobile Mirroring



VIA Site Management (VSM)



Digital Signage



Calendar Integration



VIA Pad Compatible



Integrated YouTube Player



Do Not Disturb (DND)



Web Conferencing



HDMI Input

The terms HDMI, HDMI High-Definition Multimedia Interface, and the HDMI Logo are trademarks or registered trademarks of HDMI Licensing Administrator, Inc.