

# 1. STOP

VERIFY ALL DIMENSIONS TO ENSURE THAT THIS PRINT IS 1 TO 1 SCALE.

# 2. MEASURE

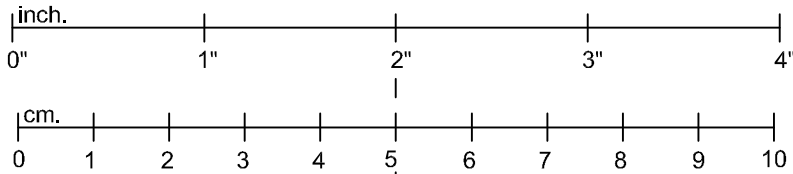

MEASURE WITH A RULER.

# 3. CUT

Document p/n:  
250-0678-006  
Page 1 of 1

THIS IS A PRECISION CUT-OUT TEMPLATE.  
DO NOT SCALE OR ADJUST!

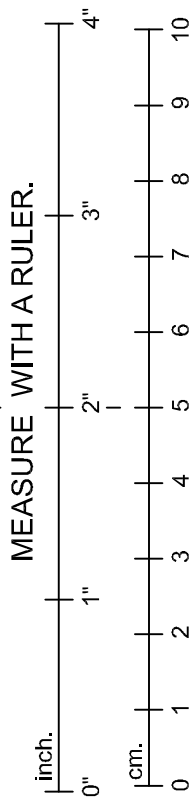

MEASURE WITH A RULER.

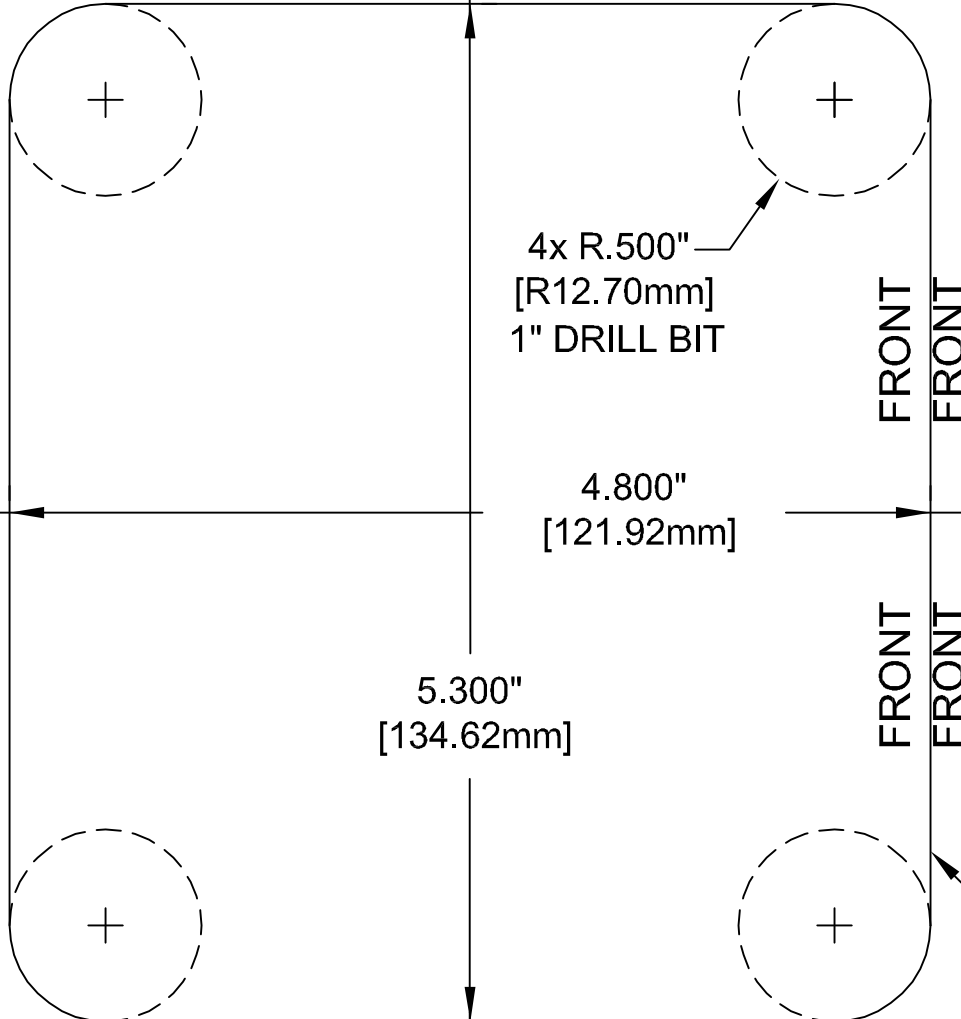

CUT TO THE OUTSIDE OF THE LINE.

ALTINEX, INC. IS NOT RESPONSIBLE FOR ANY DAMAGE TO A TABLE OR DESK.



ALTINEX, INC. MODEL NUMBERS:

TNP421	TNP421C	TNP328	TNP328S
TNP431	TNP431C	TNP320C	TNP355C
TNP441	TNP441C	TNP358	TNP358S
TNP451	TNP451C	TNP358C	

# 1. STOP

# 2. MEASURE

# 3. CUT