

1. STOP

VERIFY ALL DIMENSIONS TO ENSURE THAT THIS PRINT IS 1 TO 1 SCALE.

2. MEASURE

3. CUT

Document p/n:
250-0858-002
Page 1 of 4

4X
R.300"
[R7.62]

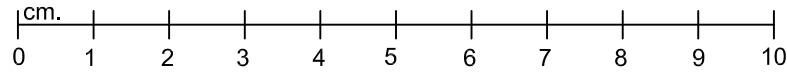
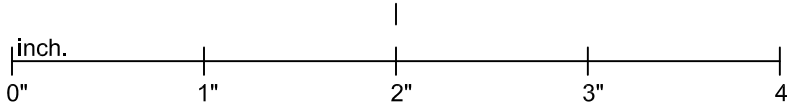

MEASURE WITH A RULER.

.100"
[2.54]
MIN. FINISHED CLEARANCE

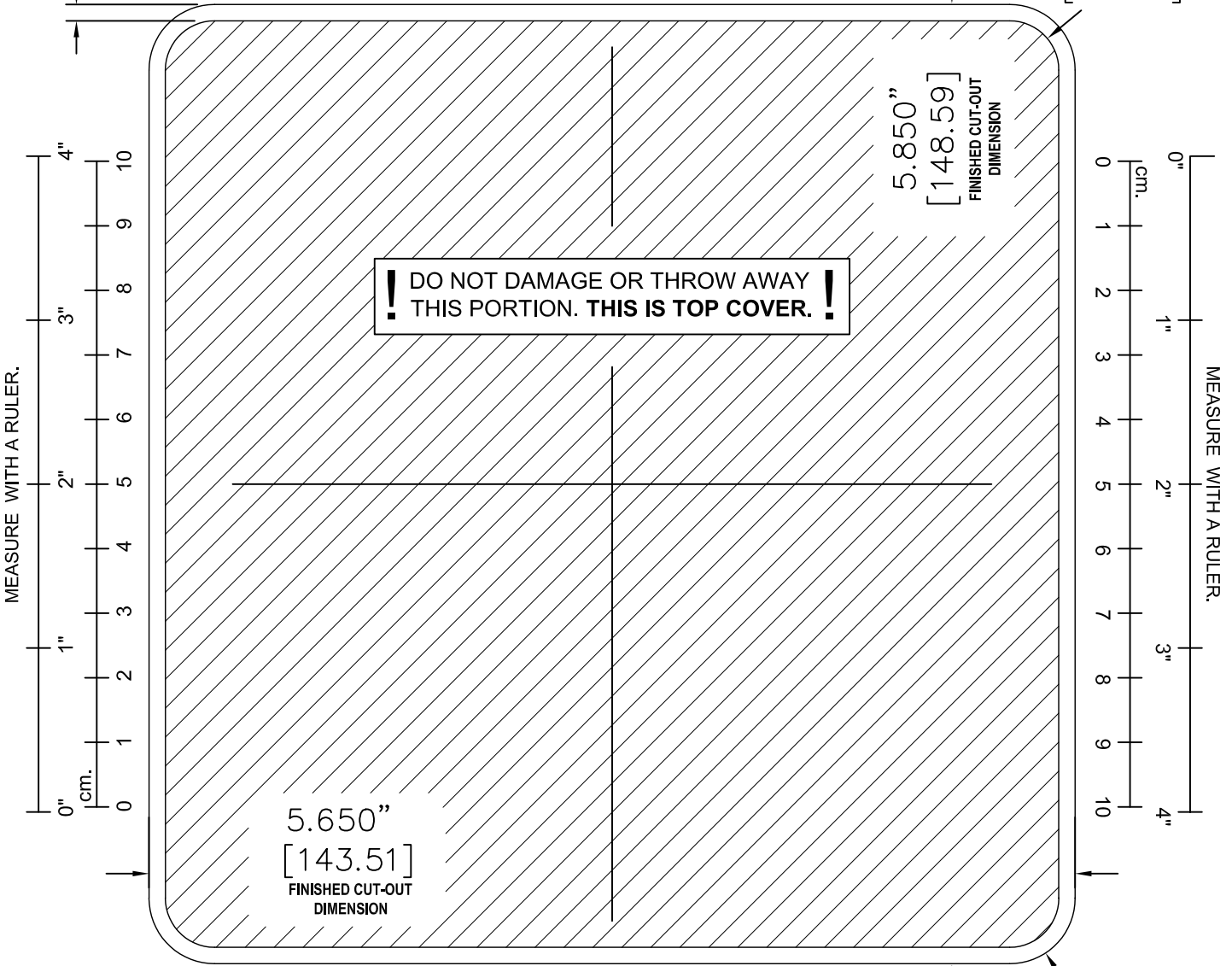

DO NOT SCALE OR ADJUST!

ALTINEX[®]
ALTINEX, INC. IS NOT RESPONSIBLE
FOR ANY DAMAGE TO A TABLE OR DESK.

ALTINEX, INC.
MODEL NUMBERS:
PNP515

4X
R.400"
[R10.16]

1. STOP

2. MEASURE

3. CUT

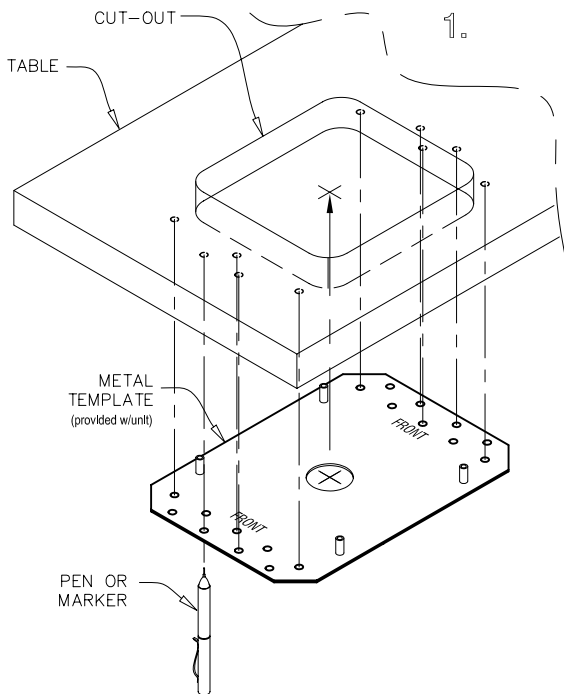

1. Once the initial cut-out has been made to the table, use metal template provided by Altinex to find the location of the pilot holes. Mark the location with a fine marker or pen.

2. Pre-drill pilot holes 10 times in the marked locations for a #6 wood screw (leave extra holes incase needed in the future use):
softwood $\text{Ø}1/16''$,
hardwood $\text{Ø}5/64''$
The pilot holes should be around .375" inches deep.

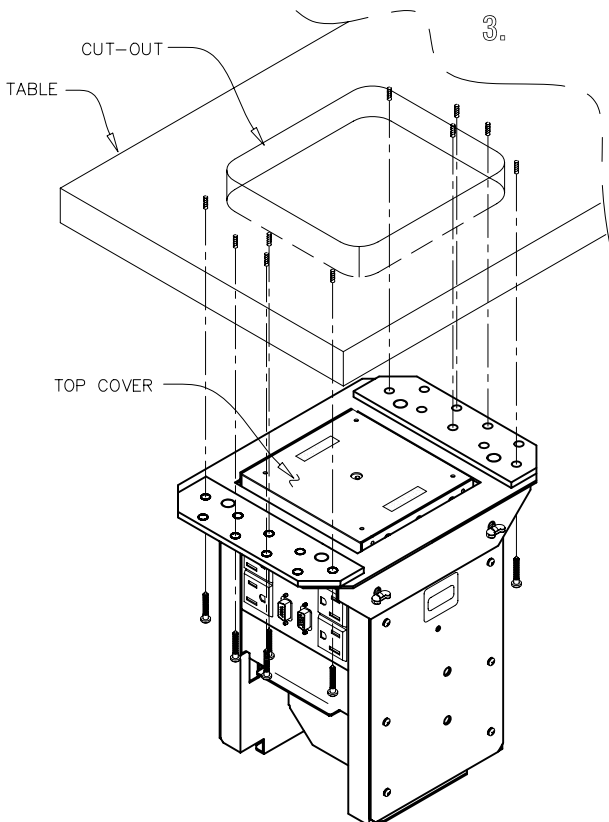
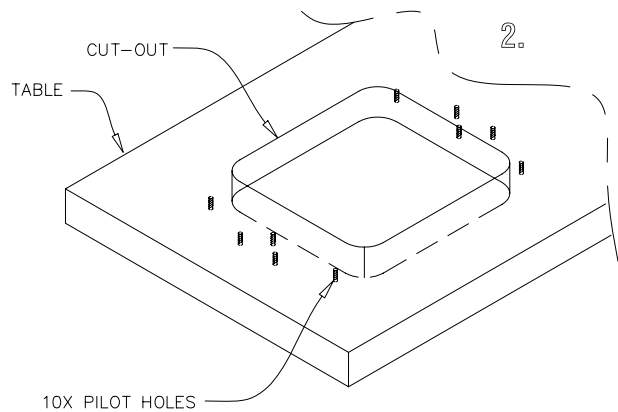

3. Take the top cover out of the packaging bag and install it on top portion of the unit. **Do not install with screws yet, wait til step6.** Secure the mounting panel with unit under the table using provided screws 3/4" long. Use screws as specified on labels in the plastic bags provided in the kit. The mounting screws that are provided with the unit should not be used on tables less than 3/4" thick.

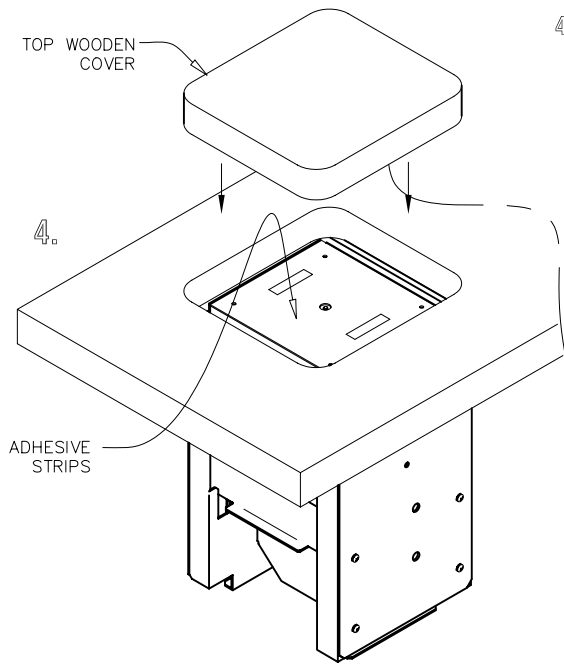

4. Close unit.
Remove top protection layer of both adhesive strips.
Place the wooden cover over the top cover with adhesive strips.

5. Align the wooden cover so that the space around the wooden cover is symmetrical. If the space is not equal from first try, peel the wooden cover off and try again, until it is aligned perfectly.

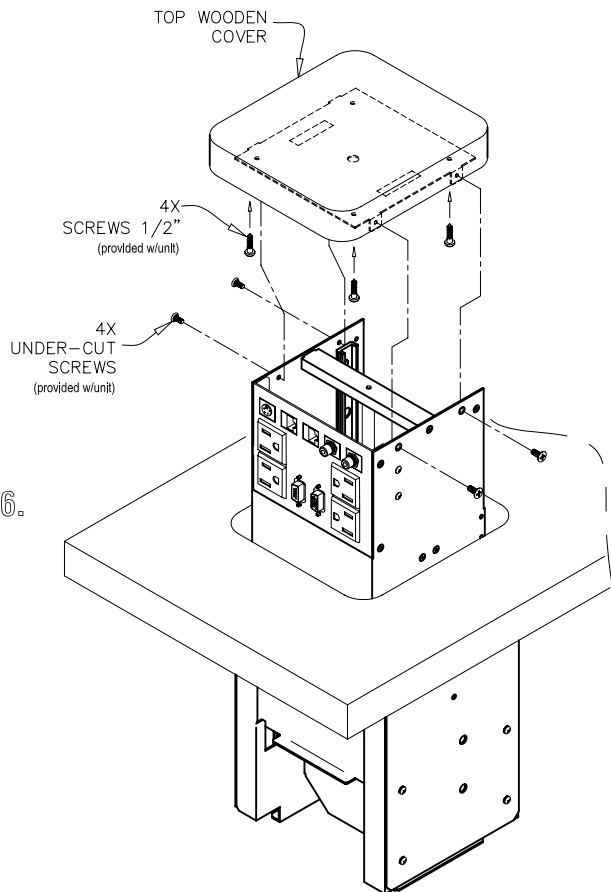
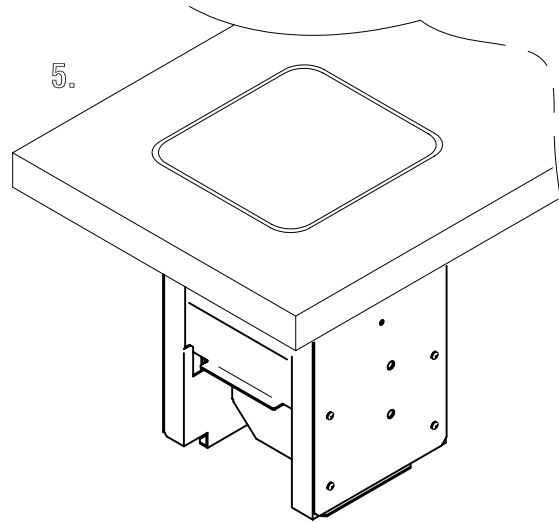

6. Once the wooden cover is aligned push on it so that the unit opens, pick-up the wooden cover along with the stuck top cover plate and mount both parts together. Pre-drill pilot holes 4 times in the hole locations for a #6 wood screw: softwood $\text{Ø}1/16''$, hardwood $\text{Ø}5/64''$. The pilot holes should be approx. $.375''$ deep. Use provided $1/2''$ screws to mount the wooden cover to the top cover panel. Then make sure the unit is up and secure the top cover to the unit using under-cut screws provided by Altinex.

THIS ILLUSTRATION IS NOT 1:1 SCALE

Document p/n:
250-0858-001
Page 3 of 4

ALTINEX®

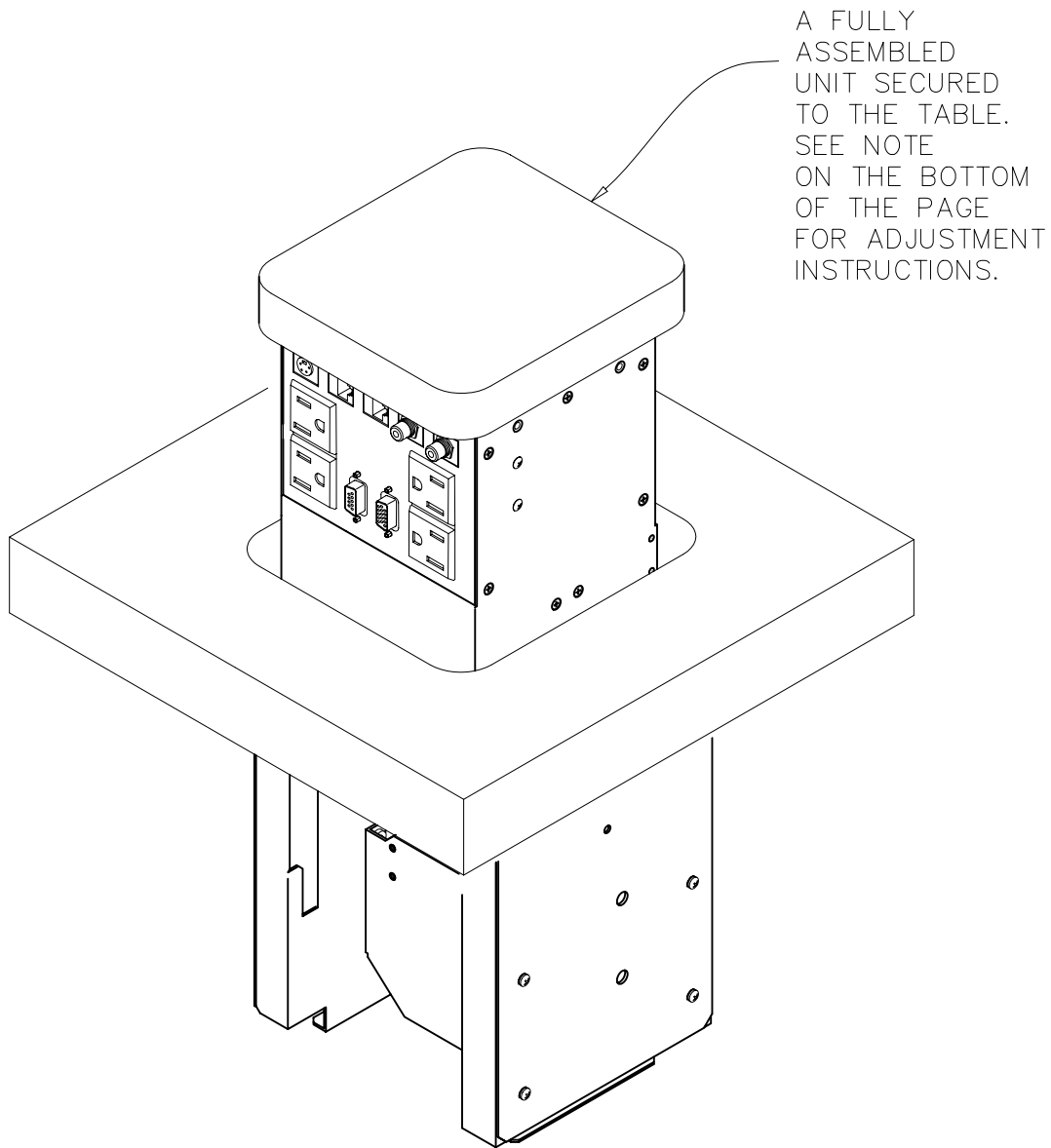

To adjust and align the unit to the surface of the table, simply:

- 1. Close the unit.*
- 2. Loosen all four wing nuts under the table.*
- 3. Press the unit down or upwards from below the desk until it aligns with the surface of the desk.*
- 4. And tighten the wing nuts below the desk.*