



# ONELINK™ FOR PRECISION 60 CAMERA

Video, Power, Network and Control Extension System over a Single Cat-5e/6 Cable at distances up to 328' (100m) featuring HDBaseT™ for use with Cisco® Precision 60 Camera and SX series codec.

## Part Numbers

999-9560-000 OneLINK System for Cisco Precision Cameras (North America)

999-9560-001 OneLINK System for Cisco Precision Cameras (International)

*(Cameras not included)*

## OneLINK HDMI Interface

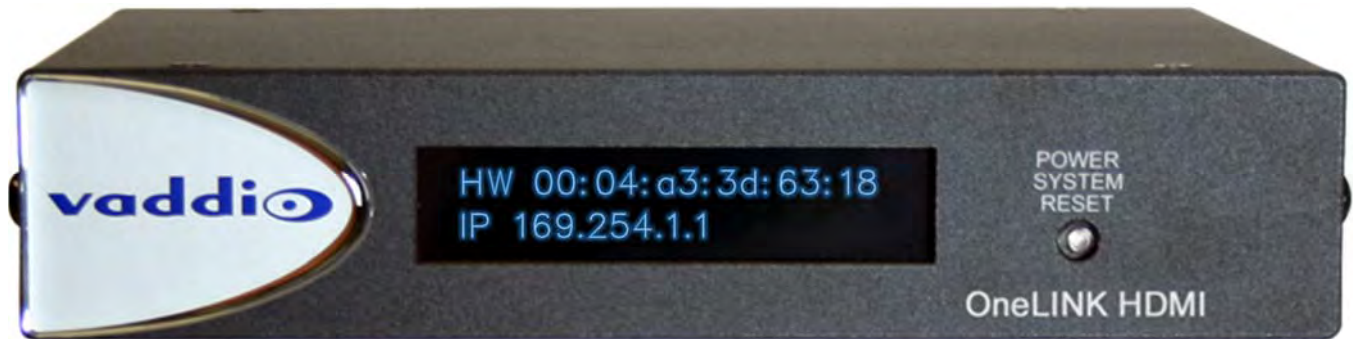

## OneLINK HDMI EZIM™ Camera Interface (camera end)



Precision 60 Camera and  
SX Codec Not Included



**vaddio**  
**HDMI™** **HDBT™**  
HIGH DEFINITION MULTIMEDIA INTERFACE ASE

## TABLE OF CONTENTS

|  |    |
|--|----|
| Overview.....  | 3  |
| Unpacking.....   | 4  |
| Image: OneLINK HDMI Interface with Front Panel Feature Call-outs .....     | 4  |
| Image: OneLINK HDMI Interface with Rear Panel Connector Call-outs.....     | 5  |
| Image: OneLINK EZIM Camera Interface with Connector Call-outs.....         | 5  |
| Determine Camera Mounting Location.....                                    | 6  |
| Camera and EZIM Mounting Instructions.....                                 | 6  |
| Image: Precision 60 Wall Mount with EZIM Attached .....                    | 6  |
| Basic System Configuration .....   | 7  |
| Installation .....   | 7  |
| Diagram: Basic Connectivity of the OneLINK System .....                    | 7  |
| Operating the OneLINK:.....  | 7  |
| OneLINK Display .....  | 8  |
| The OneLINK Screen Shot Tour .....   | 8  |
| DHCP IP Set-up (Dynamic Host Configuration Protocol).....                  | 8  |
| Static IP Set-up:.....   | 8  |
| Screen Shot: Home Page.....  | 8  |
| Screen Shot: Login.....  | 9  |
| Screen Shot: Room Labels .....   | 9  |
| Screen Shot: Networking (DHCP).....  | 10 |
| Screen SHOT: Networking (Static IP Configuration).....                     | 10 |
| Screen SHOT: Security .....  | 11 |
| Screen SHOT: Security .....  | 11 |
| Screen Shot: Diagnostics .....   | 12 |
| Screen Shot - Admin Menu - Help.....                                       | 12 |
| Screen Shot: System Menu.....  | 13 |
| Screen Shot: System Menu - Firmware Update Confirmation .....              | 13 |
| Screen Shot: System Menu - Restore Factory Settings Confirmation .....     | 14 |
| General Specifications.....  | 15 |
| Appendix 1: Connectors and signals .....                                   | 15 |
| Compliance and CE Declaration of Conformity - OneLINK HDMI Interface ..... | 16 |
| Compliance and CE Declaration of Conformity - OneLINK HDMI EZIM.....       | 17 |
| Warranty Information .....   | 18 |

## OVERVIEW

Vaddio's OneLINK System is a digital camera extension system that extends HDMI video, power network and control on a single Cat-5e/6 cable at distances of up to 328' (100m). The OneLINK system sends and regulates power to the camera, provides a bi-directional control channel for Ethernet and transmits/receives uncompressed HDMI digital video up to 1080p/60 for the Precision 60 camera.



**Images:** OneLINK HDMI Interface (above) and the OneLINK EZIM Camera Interface (right),

The system consists of the small OneLINK EZIM (EZCamera™ Interface Module) camera interface at the camera location and the OneLINK HDMI Interface. The EZIM provides the required camera connectivity and is mounted to the back of the included wall mount bracket with two 6-32 x .188" black mounting screws. All camera side cables and codec side cables are provided with the OneLINK system. The wall mount bracket can be mounted directly to a 2-gang sized electrical box for conduit installations or directly to the dry wall with wall anchors.

From one end to the other, the OneLINK system provides system integrators and end users a simplified product based on the vast experience Vaddio has in cameras and cable extension systems.



Please use this manual in conjunction with the manual for the camera attached to the OneLINK System.

### Intended Use

Before operating the device, please read the entire manual thoroughly. The system was designed, built and tested for use indoors, and with the provided power supply and cabling. The use of a power supply other than the one provided or outdoor operation has not been tested and could damage the device and/or create a potentially unsafe operating condition.

### Save These Instructions

The information contained in this manual will help you install and operate your product. If these instructions are misplaced, Vaddio keeps copies of Specifications, Installation and User Guides and most pertinent product drawings for the Vaddio product line on the Vaddio website. These documents can be downloaded from [www.vaddio.com](http://www.vaddio.com) free of charge.

### Important Safeguards

Read and understand all instructions before using. Do not operate any device if it has been dropped or damaged. In this case, a Vaddio technician must examine the product before operating. To reduce the risk of electric shock, do not immerse in water or other liquids and avoid extremely humid conditions.



**Use only the power supply provided with the system. Use of any unauthorized power supply will void any and all warranties.**

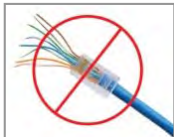

**Please do not use "pass-thru" type RJ-45 connectors. These pass-thru type connectors do not work well for professional installations and can be the cause of intermittent connections. For best results please use standard RJ-45 connectors, real crimpers and test all cables for proper pin-outs prior to use and connection to Vaddio Cat-5e/6 products.**

### Important Note

OneLINK systems are not compatible with previous versions of OneLINK codec camera extenders. The specifications are different and will not function if parts from either system are mixed. The older systems are those with Quick-Connect part number 998-1105-019 and EZIM part number 998-6700-003. Connecting these to a new OneLINK system may cause failure and void warranty.

## Unpacking

Carefully remove the product and all of the included parts from the packaging. Identify the following parts:

### OneLINK System for Precision 60 (North America)

#### Part Number 999-9560-000 Includes:

- One (1) 998-1105-043 OneLINK HDMI Interface
- One (1) 998-6700-043 OneLINK EZIM Camera Interface
- One (1) Vaddio 48 VDC, 1.36 Amp Switching Power Supply with North American AC Cord Set
- One (1) 12" (305mm) HDMI M to M Video Cable (camera side)
- One (1) 12" (305mm) Cat-5e Network Patch Cable (camera side)
- One (1) 12" (305mm) Camera Power Cable (camera side)
- One (1) 36" (915mm) Cat-5e Network Control Cable (codec side)
- One (1) 36" (915mm) HDMI M to M Cable (codec side)
- One (1) Wall Mount Bracket with mounting hardware
- Two (2) 6-32 x .188" Black Phillips head screws to mount EZIM to the Wall Mount
- One (1) Quick Start Guide

**(Camera not included)**

### OneLINK System for Precision 60 (International)

#### Part Number 999-9560-000 Includes:

- One (1) 998-1105-043 OneLINK HDMI Interface
- One (1) 998-6700-043 OneLINK EZIM Camera Interface
- One (1) Vaddio 48 VDC, 1.36 Amp Switching Power Supply
- One (1) Euro Power Cord
- One (1) UK Power Cord
- One (1) 12" (305mm) HDMI M to M Video Cable (camera side)
- One (1) 12" (305mm) Cat-5e Network Patch Cable (camera side)
- One (1) 12" (305mm) Camera Power Cable (camera side)
- One (1) 36" (915mm) Cat-5e Network Control Cable (codec side)
- One (1) 36" (915mm) HDMI M to M Cable (codec side)
- One (1) Wall Mount Bracket with mounting hardware
- Two (2) 6-32 x .188" Black Phillips head screws to mount EZIM to the Wall Mount
- One (1) Quick Start Guide

**(Camera not included)**

### Image: OneLINK HDMI Interface with Front Panel Feature Call-outs



1. **Blue Backlit Display:** A two row, 20 character display displays the IP and MAC addresses for access to internally served web pages. These web pages are currently used only for easy firmware updates in the unlikely event the OneLINK system ever requires a firmware update.
2. **Power / System Reset:** Blue power indicator lamp and recessed momentary reset button indicates presence of power with a blue LED. Press this recessed button for a system reset if required.

**Image: OneLINK HDMI Interface with Rear Panel Connector Call-outs**

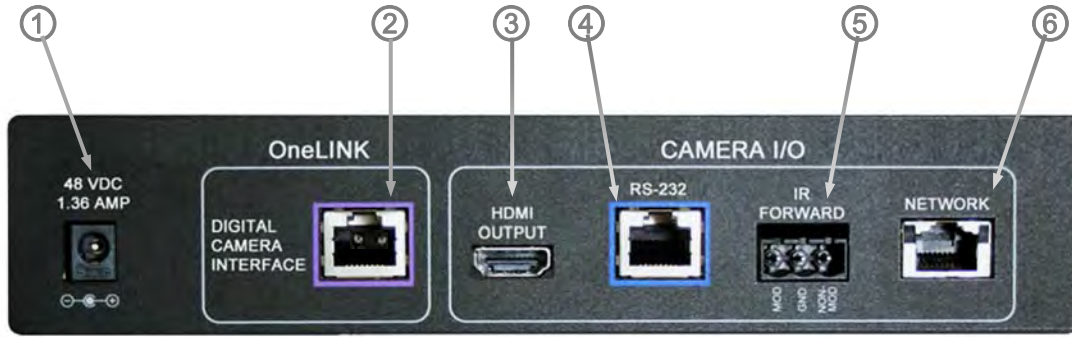

1. **Power Input Jack:** Coaxial 5.5mm OD x 2.5mm ID power jack with positive center for use with supplied 48VDC, 1.36A power supply. This power jack supplies power to both ends of the OneLINK system as well as the camera.
2. **OneLINK Interface Port:** Shielded RJ-45 jack for connecting a single Cat-5e or better cable for connectivity to the EZIM (TX) at the camera location to the OneLINK HDMI Interface (Rx). Cat-6 or Cat-7 cabling might provide better performance in noisier RF or EMF environments - when in doubt, use shielded Cat-6 cable. Cable distance between the OneLINK EZIM and OneLINK HDMI Interface is a maximum of 328 feet (100 m).
3. **HDMI Output:** HDMI output to provide camera HDMI signal.
4. **RS-232 port:** Shielded RJ-45 jack for connecting a bi-directional RS-232 signal to be transported by the OneLINK system (if required). This signal will be transported on the OneLINK system simultaneously with the other signals
5. **IR Forwarding:** 3-pin Phoenix-style connector for forwarded IR signals from the camera EZIM. Modulated and non-modulated outputs provided. **Note:** IR Forwarding is not used with the Precision 60 camera and SX series codecs.
6. **Network IP Port:** Shielded RJ-45 network jack for transport of Ethernet signals for camera control or webserver access.

**Image: OneLINK EZIM Camera Interface with Connector Call-outs**

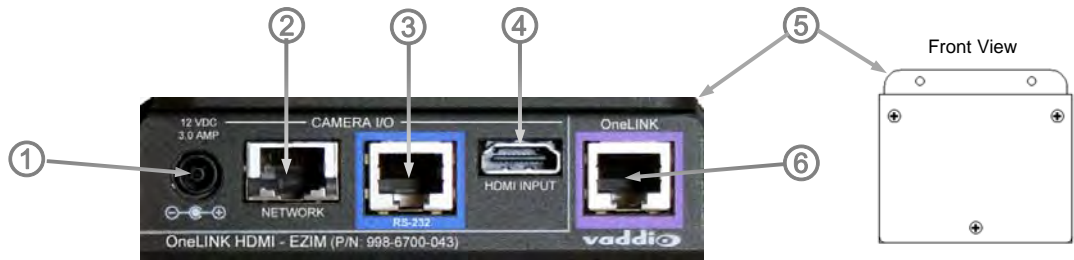

1. **Camera Power Jack:** EIAJ-04 coaxial power connection to provide power to the camera. An appropriate cable is provided to connect the camera to this jack.
2. **Ethernet Port:** Shielded RJ-45 network jack provided to allow connection of Ethernet control to the camera.
3. **RS-232:** Shielded RJ-45 jack for bi-directional RS-232 connection to camera.
4. **HDMI Connection:** HDMI connector for HDMI video signal coming from the camera to be inserted into the EZIM for transport.
5. **Mounting flange:** A convenient mounting flange is provided for mounting the EZIM to the camera's included wall mount or to another appropriately located position.
6. **OneLINK Interface Port:** Shielded RJ-45 jack for connecting a single Cat-5e or better cable for connectivity to the EZIM (TX) at the camera location to the OneLINK HDMI Interface (Rx). Shielded Cat-6 cabling will provide better performance in noisier RF or EMI environments - when in doubt, use shielded Cat-6 cable. Cable distance between the OneLINK EZIM and OneLINK HDMI Interface is a maximum of 328 feet (100 m).

### DETERMINE CAMERA MOUNTING LOCATION

When locating the camera, consider viewing angles, lighting conditions, possible line of site obstructions and check for in-wall or in-ceiling obstructions where the camera is to be mounted. Always pick a mounting location to optimize the performance of the camera. Please locate the camera to enable easy positioning of the camera body with the ability to point down and away from the ceiling and a pile of fluorescent lighting cells. *Cameras generally don't like to be swamped with fluorescent light and nobody sits on the ceiling anyway.*

After determining the optimum location of the camera system, pull and route the required Cat-6 cable from the Camera/EZIM location back to the OneLINK Interface location (head-end).

### CAMERA AND EZIM MOUNTING INSTRUCTIONS

The wall mount for the HDMI Cameras has two threaded 6-32 inserts on the back of the mount to attach EZIM to the Mount. The camera platform has four (4) small holes for mounting the camera to the mount with the provided M3 x 6mm pan head screws platform. It also has a slot for a 1/4"-20 screw that is not used with the Polycom camera.

If the wall mount is to be mounted on a 2-gang wall box, use the screws supplied with the wall box cover plate to attach Thin Profile Wall Mount Bracket. If mounting to drywall with wall anchors, use the four (4) quality wall anchors and screws provided with the mount. The Thin Profile Wall Mount Bracket's mounting holes are slotted and are 90° opposing to provide easy leveling. Level the mount and place the camera on the mount. 

The OneLINK Kit for the Precision 60 includes two (2) 6-32 x .188" pan head screws. Use these screws to attach the EZIM to the back of the mount.

Use the provided 1/4"-20 mounting screw to attach the camera to the mount. This step is best performed after the camera and EZIM are cabled (see next page).

#### Image: Precision 60 Wall Mount with EZIM Attached

**Note:** The mount may look slightly different than the mount depicted.

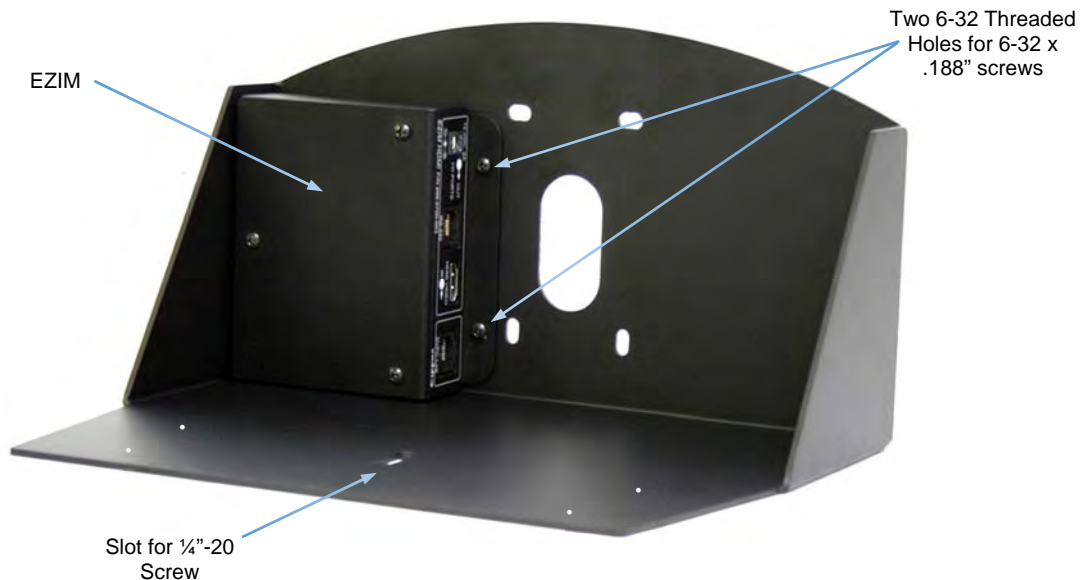

### BASIC SYSTEM CONFIGURATION

The OneLINK HDMI EZIM and OneLINK HDMI Interface are connected to each other via one Cat-6 cable plugged into the purple "OneLINK" ports at either end.

#### Installation

**Step 1:** Connect the 1' (305mm) Mini HDCI to fan-out cable (EIAJ-04 power plug, the RS-232/IR Cat-5e with RJ-45 plug and HDMI plug) from the OneLINK EZIM to the camera.

**Step 2:** Connect the OneLINK ports with a quality Cat-5e/6. In noisier RF or EMF environments - when in doubt, use shielded Cat-6 cable. Cable distance between the OneLINK EZIM and Interface is a maximum of 328 feet (100 m) on Cat-6.

**Step 3:** At the codec side, connect HDCI connector to the codec and the HDMI plug, RJ-45 plug for RS-232 and a single cable whip (for non-modulated IR) to the OneLINK interface. Connect the supplied 48 VDC, 1.36 Amp power supply to the OneLINK Interface and the codec/camera will boot up and will be ready for operation

Please see the camera manual for setup and configuration of the video and other camera settings.

#### Diagram: Basic Connectivity of the OneLINK System

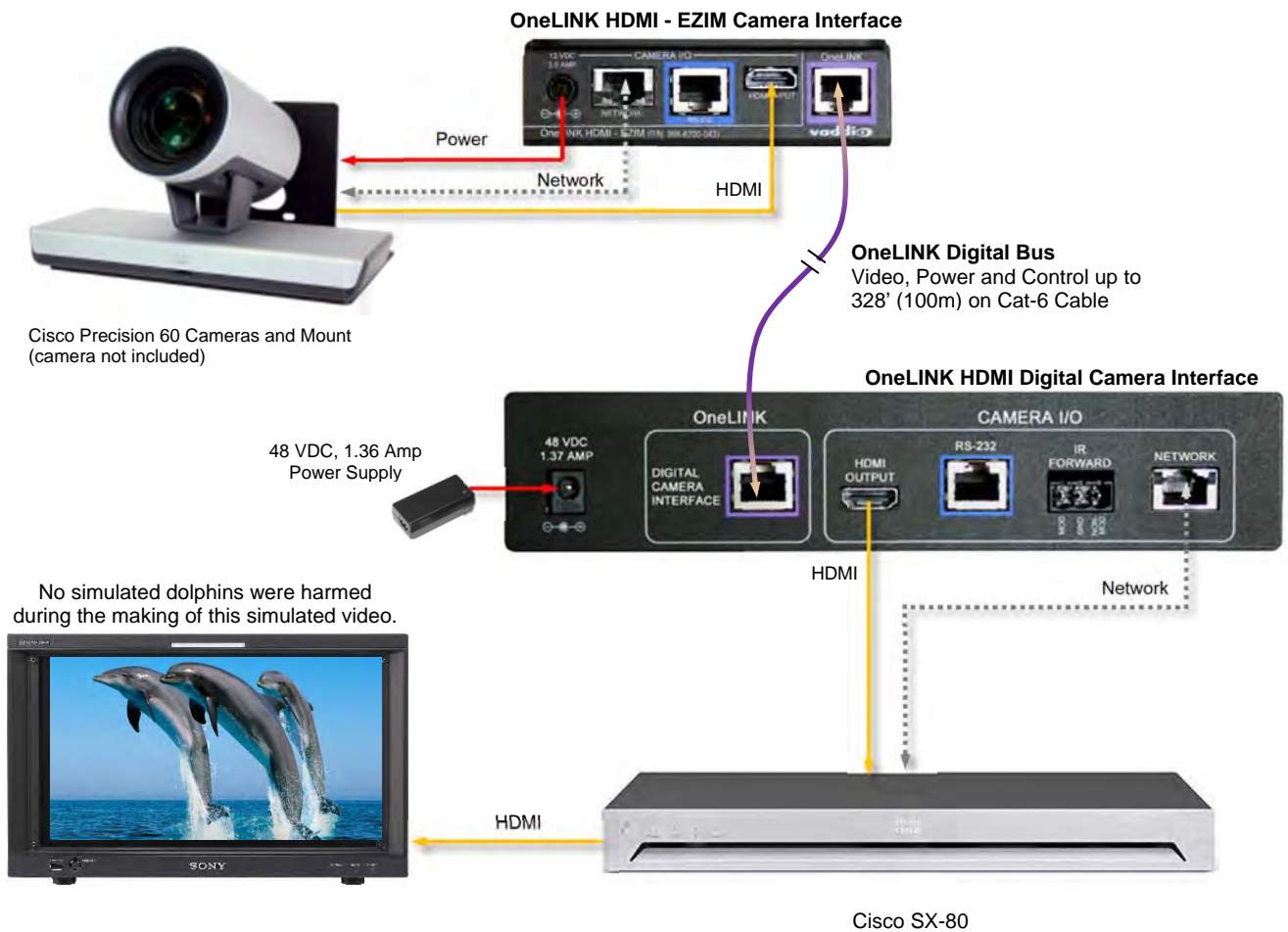

#### Operating the OneLINK:

Power up OneLINK system, then bring up the codec. Camera should function as it would without an extension system. There are very few points regarding operation, it is designed to be plug-n-play.

### ONELINK DISPLAY

The OneLINK HDMI Interface that has a 2-line LCD that displays the interfaces IP and MAC (HW for hardware) addresses. This is used to access the embedded web server for future firmware updates in the unlikely event they are ever required.

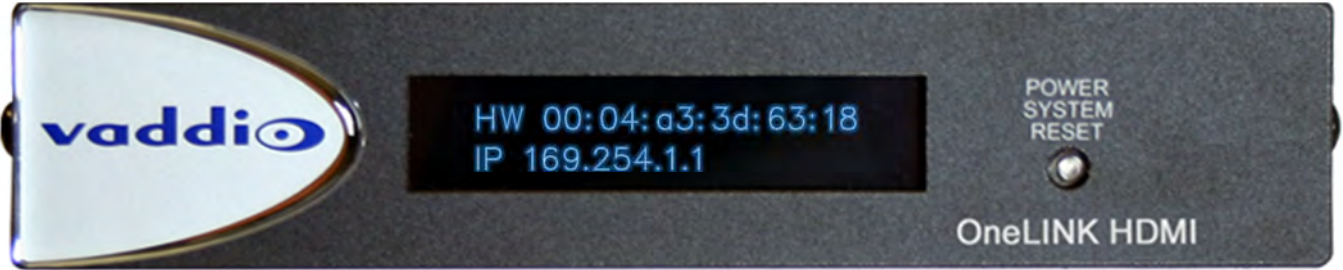

### Web Page Configuration and Structure

To access the Configuration pages served by the OneLINK, connect the Network port to either a Network or PC. This Ethernet connection to the Quick-Connect is required and will use the IP address displayed on the front of the unit. If DHCP is configured on the network, the display will show the assigned address allowing access to the web pages.

### THE ONELINK SCREEN SHOT TOUR

The OneLINK Interface uses a Linux OS and has a built-in web server. The internal web pages will allow configuration and simple control of the interface via Ethernet network connection. These web pages will allow the user or administrator to set security passwords, change the IP address, view diagnostics, access the firmware upgrade page and many more exciting things.

### DHCP IP Set-up (Dynamic Host Configuration Protocol)

DHCP Set-up (skip this section if Static IP). If the LAN has a DHCP (dynamic host configuration protocol) server, then the IP address, gateway and routing information will automatically be assigned. The software is defaulted to DHCP and will attempt to dynamically obtain an IP address using DHCP, but it will fall back to the default address of (169.254.1.1) if no DHCP server can be found.

### Static IP Set-up:

The static IP can be assigned either through the network or directly to a computer using a cross-over cable. Depending on the age of the computer, you may not need a cross-over cable. Either way the steps are the same for network or direct connection to a computer. The default address of the camera is 169.254.1.1 and the Subnet mask is 255.255.0.0. Different computer OS types all have their own way of doing things (without question), but they are essentially doing the same stuff, changing the IP address so the web pages are accessible.

### Screen Shot: Home Page

The Home Page Contains the Admin Login tabs and the Vaddio Technical Support contact information. Both the Admin and the User may access this page.

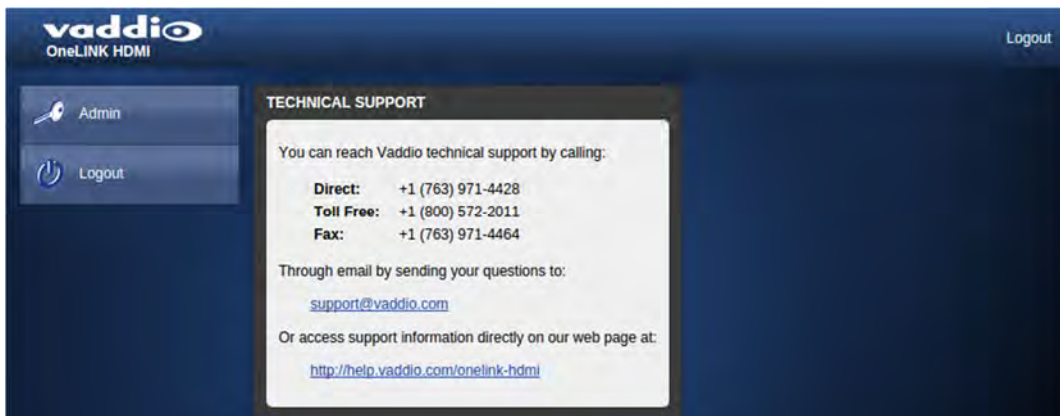



### Screen Shot: Login

By clicking on the Admin tab, the Admin Login password field appears.

- By default, the password for the admin account is: *password*

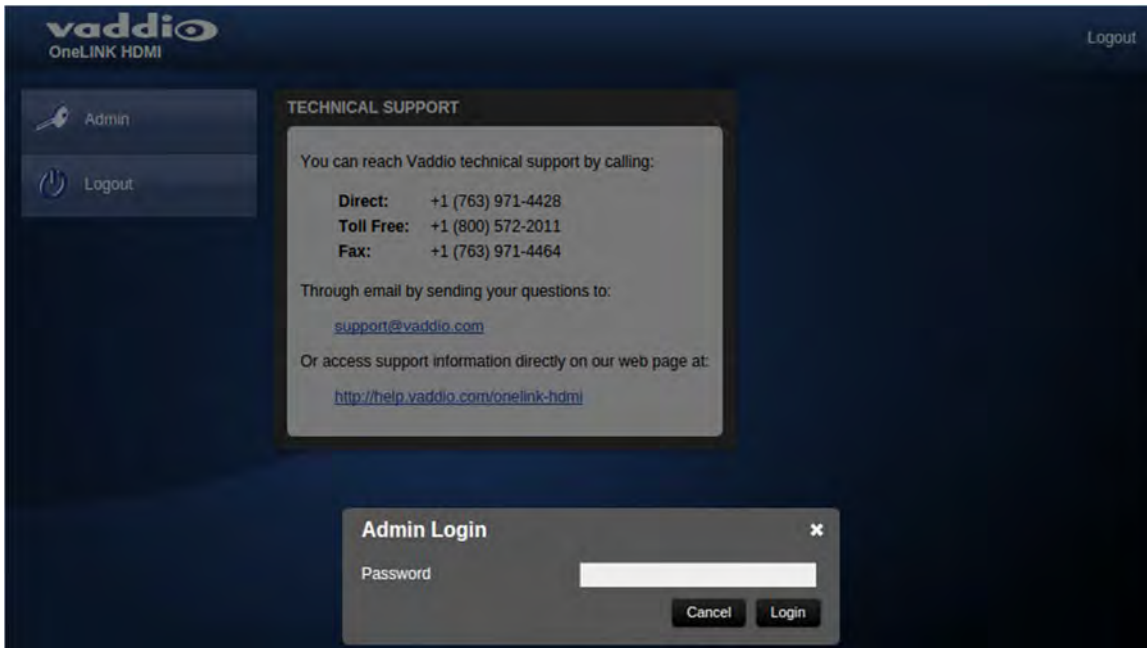

### Screen Shot: Room Labels

The Room Labels menu allows the Admin to label the company name, room name, room phone and help phone on a per OneLINK Interface basis. The labels appear on every page at the top/middle of the page. Simply enter the room information and click Save.

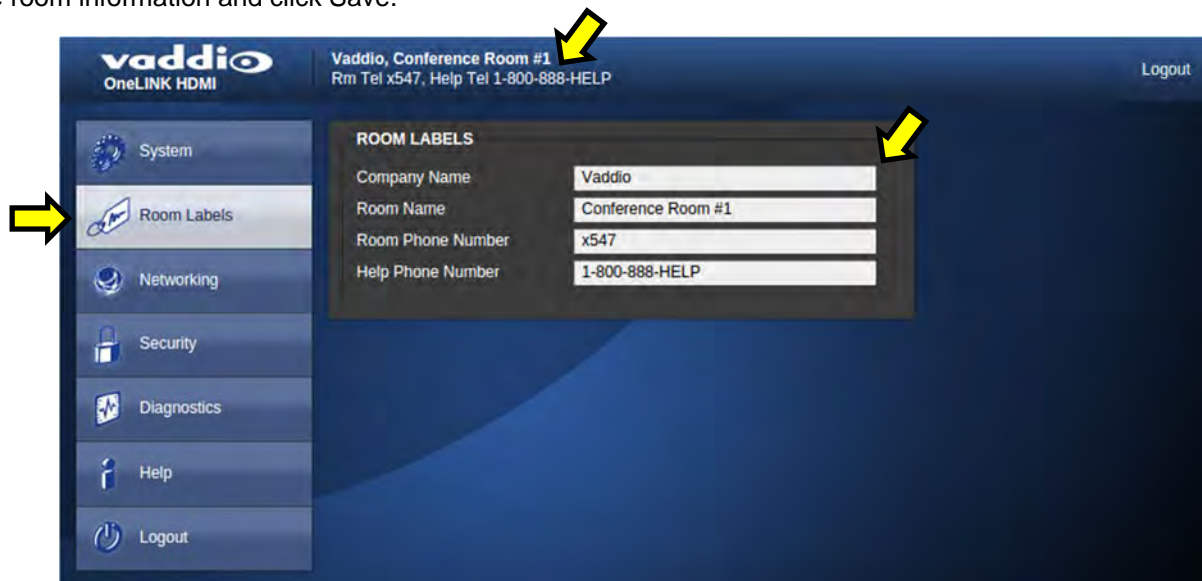

### Screen Shot: Networking (DHCP)

Under the Networking menu tab, the Network Configuration and Network Interfaces are displayed. This is where the Network administrator assigns either DHCP or a Static address and the associated parameters.

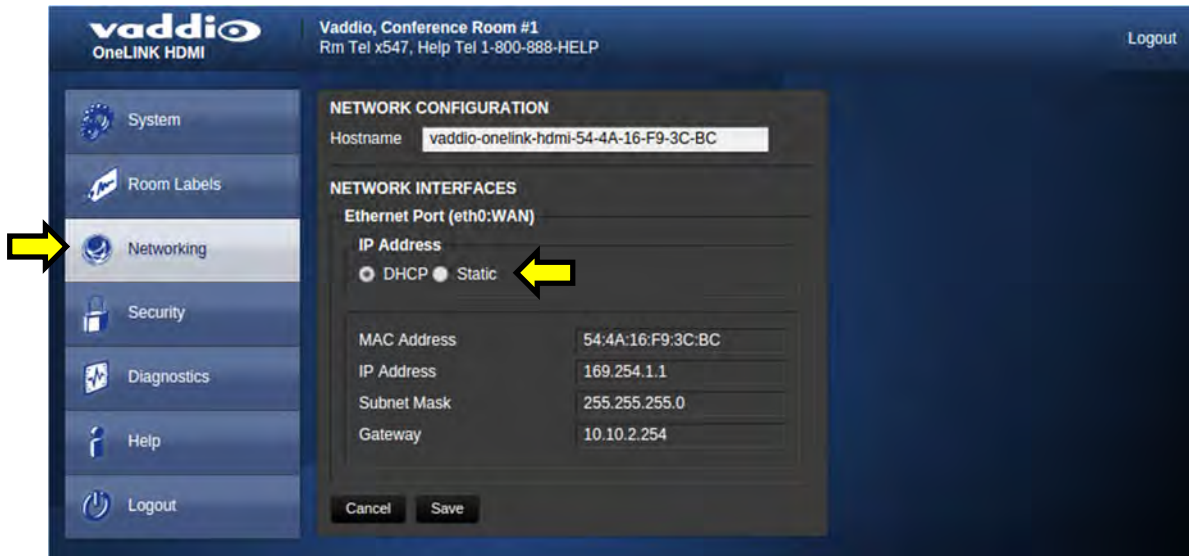

**Notes:** If the LAN has a DHCP (dynamic host configuration protocol) server, then the IP address, gateway and routing information will automatically be assigned. The software is defaulted to DHCP and will attempt to dynamically obtain an IP address using DHCP, but it will fall back to the default address of (169.254.1.1) if no DHCP server can be found.

### Screen SHOT: Networking (Static IP Configuration)

If Static IP is used, the IP Address, Subnet Mask and Gateway are manually entered. Click on Save to keep the Static IP information.

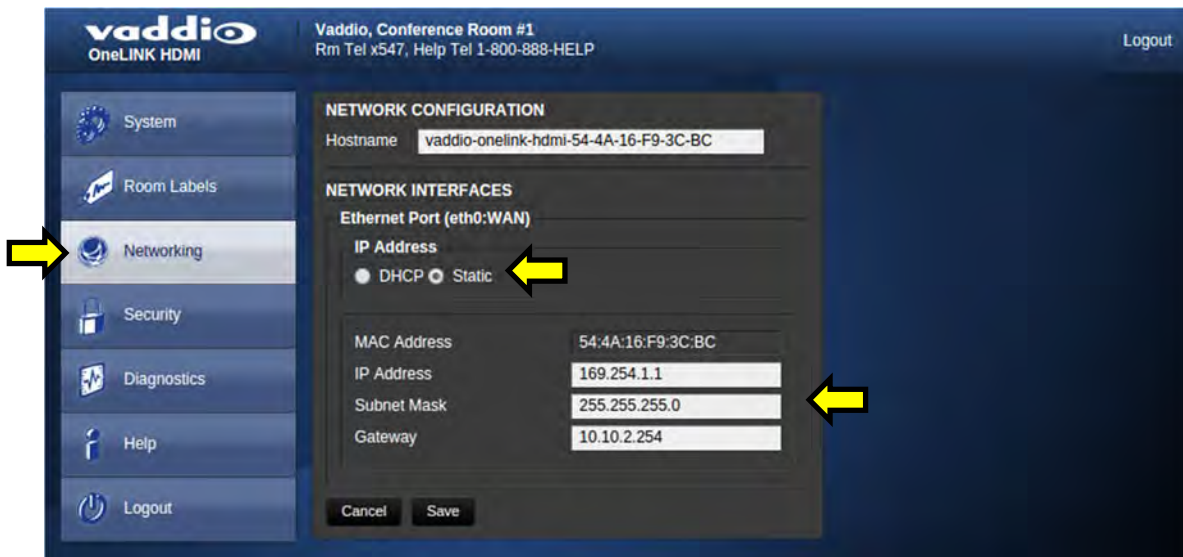

### Screen SHOT: Security

The Security menu allows the Admin to set the Admin password. In the future there will be a User access password for camera control with Vaddio PTZ cameras using the OneLINK Systems. The Guest Access function is also a future parameter that is inactive. There is only one Admin password at any given time. If changes are made, click on Save to store the change (it's best to write down the password).



### Screen SHOT: Security

After clicking the Edit Password button, an Edit Admin Password pop-up menu will appear. Enter and confirm the new Admin password and click Save to enter.

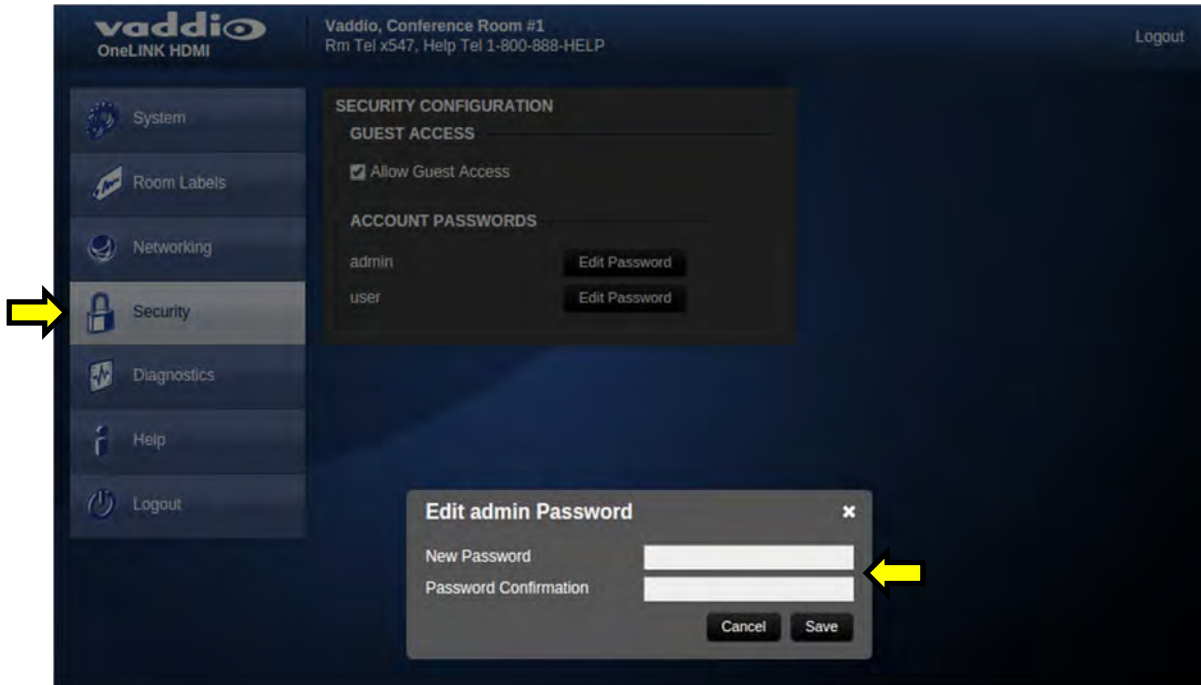

### Screen Shot: Diagnostics

Diagnostics menu button will display a set of self-diagnostics. These diagnostics may help the Vaddio technical support team diagnose a problem with the camera. The controls include Download, Refresh, Clear and Restore.

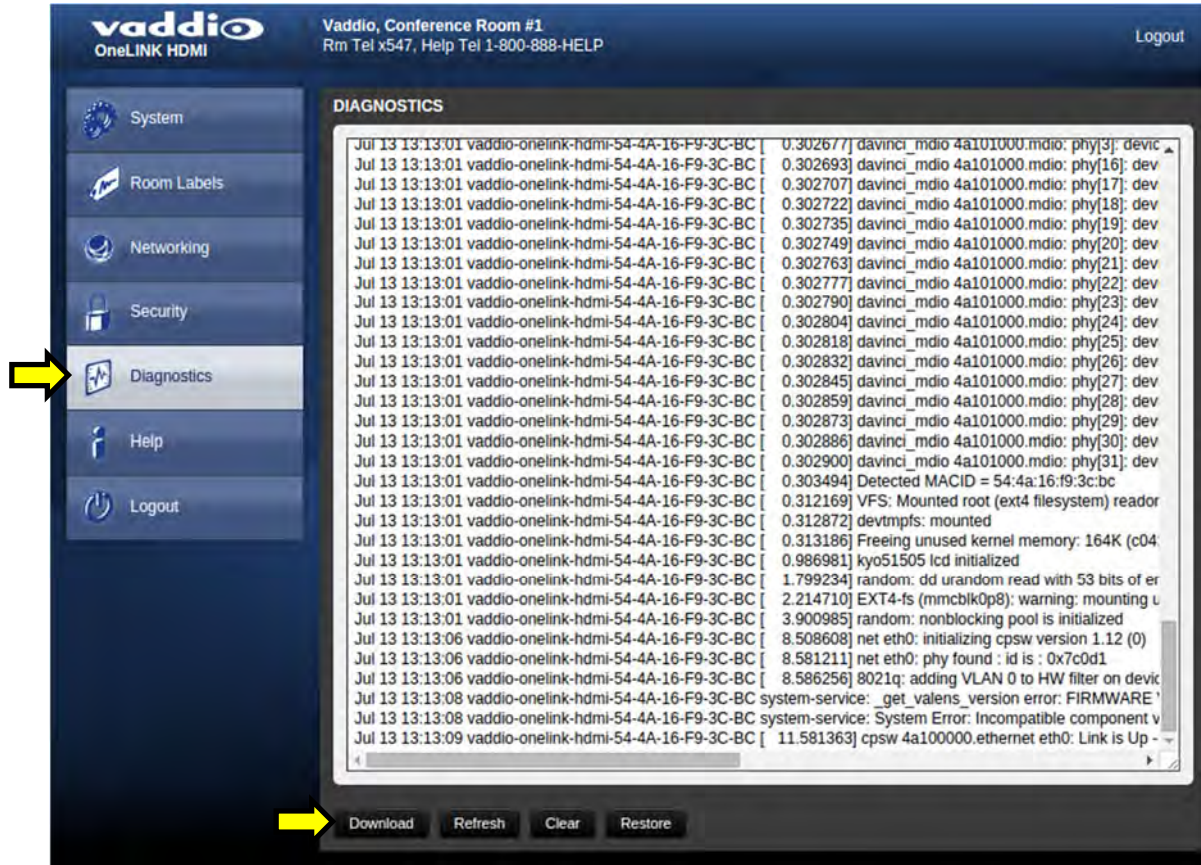

### Screen Shot - Admin Menu - Help

Service/Help information can be found under the Help menu. Support phone numbers and e-mail, manuals, FAQ's and System information is listed on support@vaddio.com.

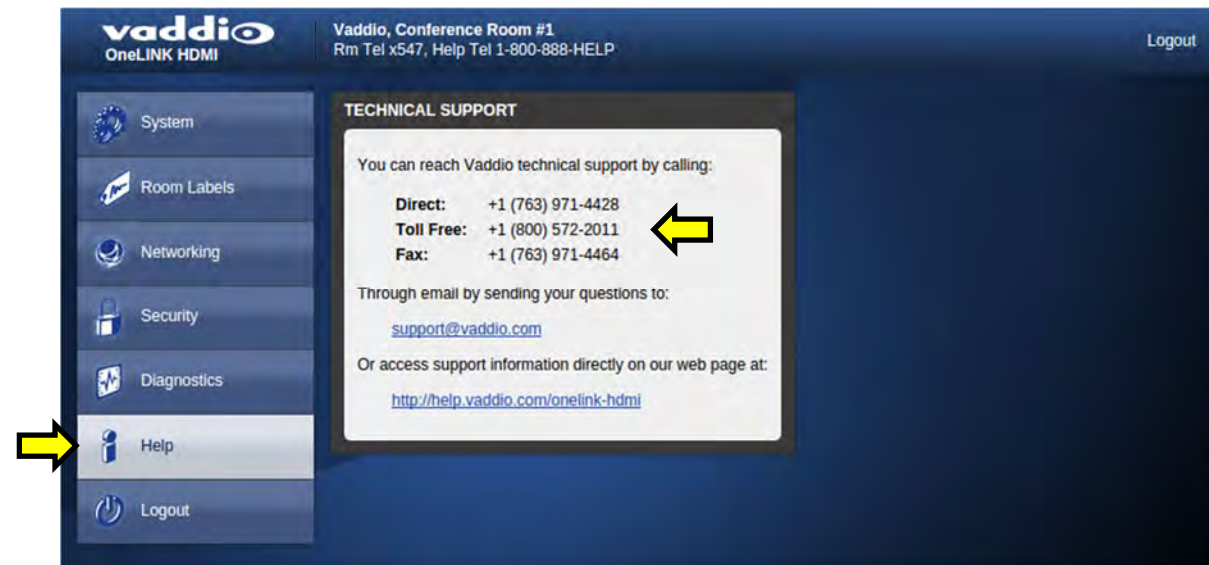

### Screen Shot: System Menu

The System Menu is where the System Info is displayed and Firmware Updates are performed. There will be firmware updates and upgrades over the life of the OneLINK Interface. The file for the firmware update is chosen in this menu and the update is started here too. A remote system Reboot and Restore to Factory Presets is also available.

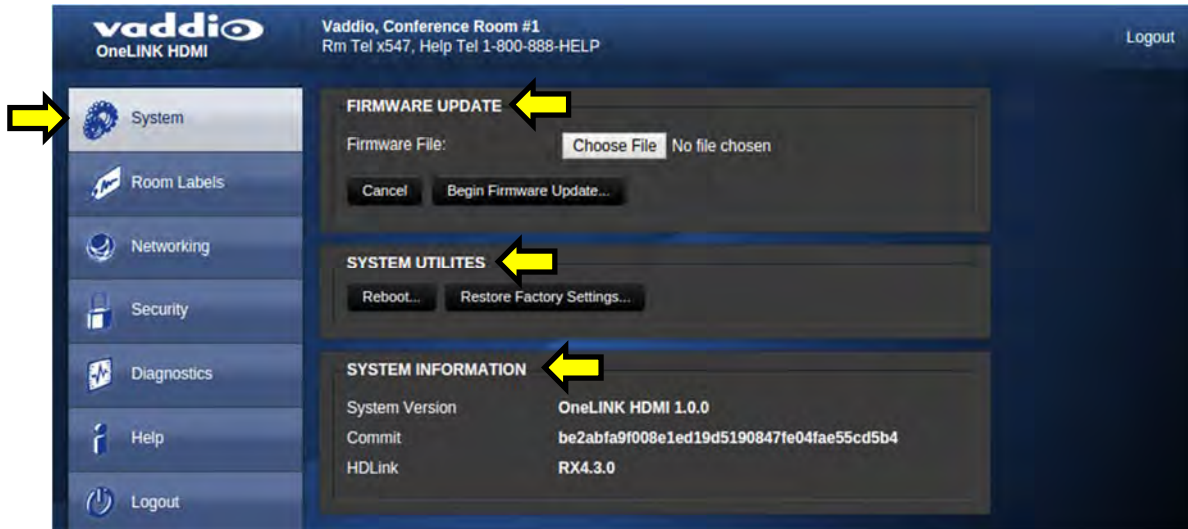

### Screen Shot: System Menu - Firmware Update Confirmation

After the firmware update file has been chosen and Begin Firmware Update is clicked, a confirmation message pop-up is shown. Click on continue or cancel one the content of the pop-up is understood.

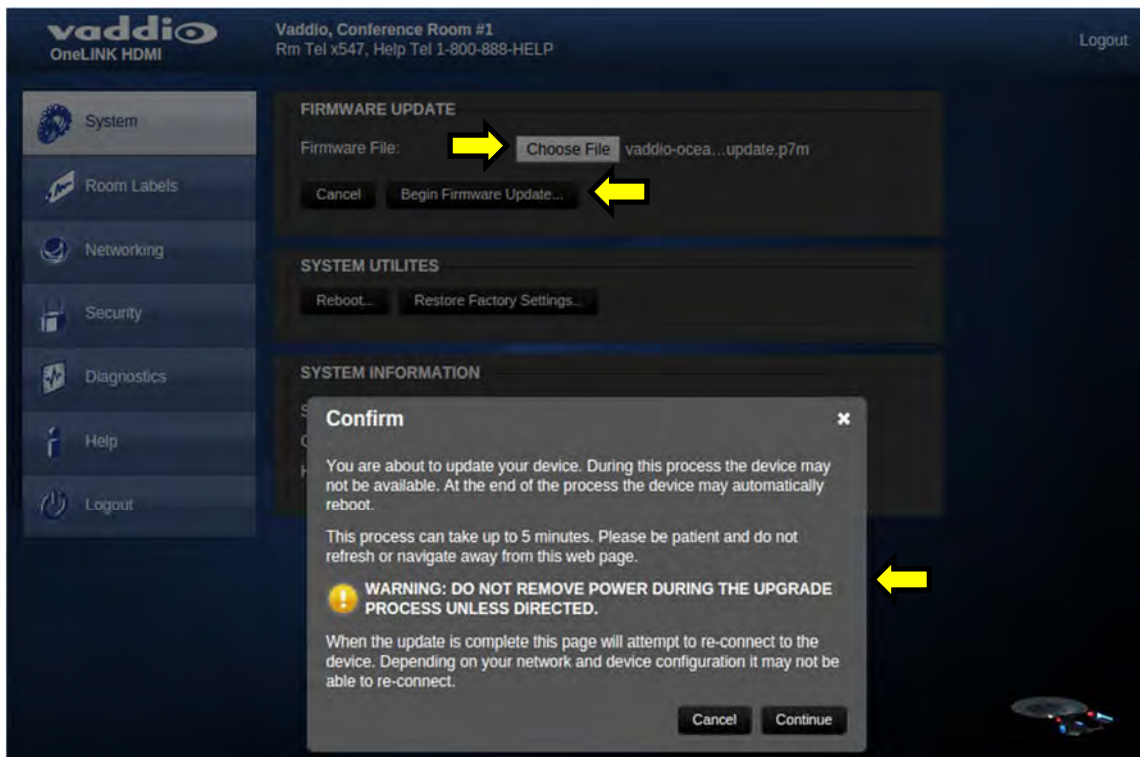

### Screen Shot: System Menu - Restore Factory Settings Confirmation

After clicking on Restore Factory Settings, a confirmation message pop-up is shown. Click on continue or cancel one the content of the pop-up is understood.

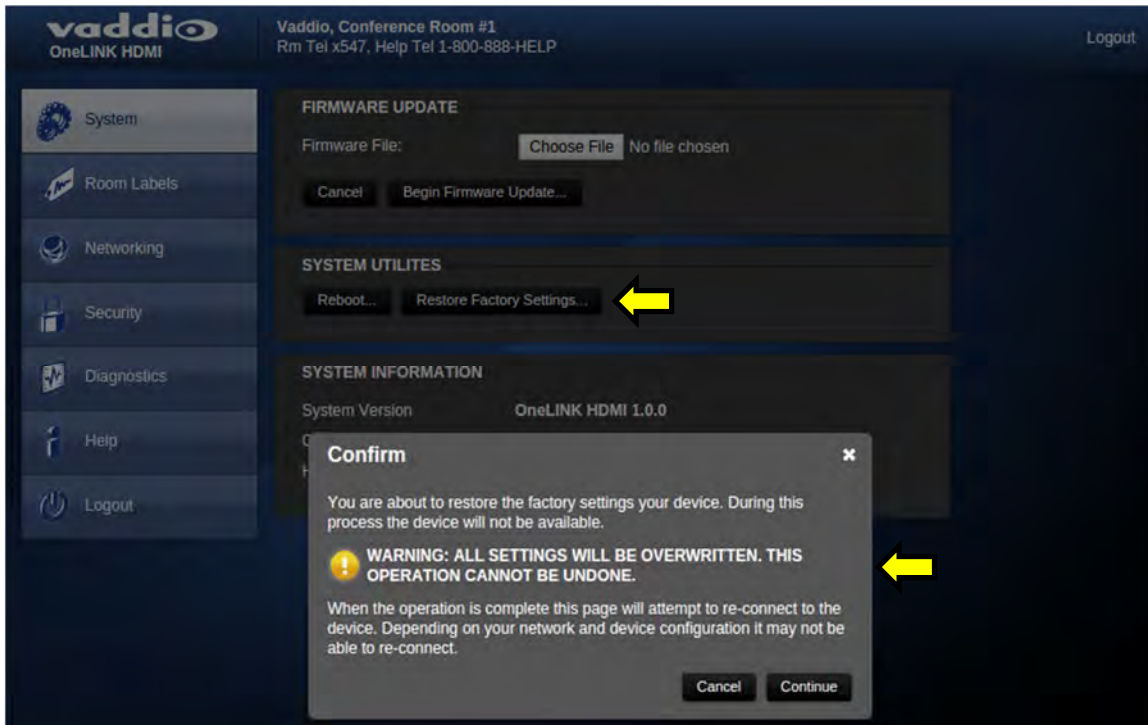

### Screen Shot: System Menu - Temperature Fault

With HDBaseT technologies, the transmit side (EZIM on the camera end) can tend to run warm, which is very normal. If the system detects that the temperature is too high, a temperature fault banner will appear and give direction to reboot or power cycle the system.

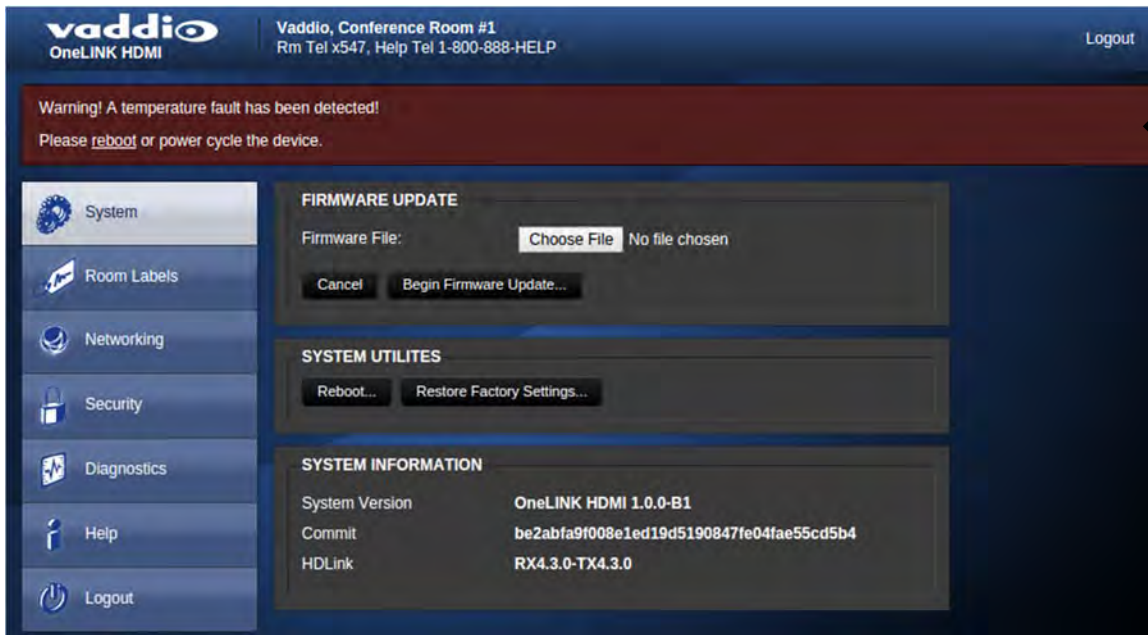

This concludes the Screen Shot Tour for the OneLINK HDMI Interface. The General Specifications, Pin-outs, Declaration of Compliance and Warranty Statement are to follow and are as breathtaking and stimulating as one would expect.

**GENERAL SPECIFICATIONS**

| <b>OneLINK System for Precision 60</b> |  |
|--|--|
| <b>Part Numbers</b>                    | 999-9560-000: OneLINK System for Precision 60 Camera (North America)<br>999-9560-001: OneLINK System for Precision 60 Camera (International)   |
| <b>Included cables</b>                 | One (1) 12" (305mm) HDMI cable(camera side)<br>One (1) 12" (305mm) Cat-5e Patch Cable (camera side)<br>One (1) 12" (305mm) Camera power cable(camera side)<br>One (1) 36" (915mm) Cat-5e Patch Cable (codec side)<br>One (1) 36" (915mm) HDMI cable (codec side) |
| <b>Video Support</b>                   | HDMI resolutions up to 1080p/60 for Precision 60 camera. The OneLINK architecture will support up to 2160p/30...for the future.  |
| <b>RS-232 Support</b>                  | Pass-through   |
| <b>Ethernet Support</b>                | Pass-through   |
| <b>Camera Power Support</b>            | 12 VDC, 3 Amp at EZIM  |
| <b>Cabling Distances</b>               | Up to 328' (100m) over Cat-5e/6  |
| <b>OneLINK Interface Power Supply</b>  | 48 VDC, 1.36 Amp   |
| <b>Connectors on OneLINK Interface</b> | OneLINK Port on Shielded RJ-45F, HDMI Output Receptacle, Ethernet on shielded RJ-45F with LEDs, RS-232 on shielded RJ-45 connector, Power in on 5.5mm OD x 2.5mm ID Coaxial connector (positive Center), IR Forward on 3-pin Phoenix-style connector             |
| <b>Connectors on OneLINK EZIM</b>      | OneLINK Port on Shielded RJ-45F, HDMI Input Receptacle, Ethernet on shielded RJ-45F with LEDs, RS-232 on shielded RJ-45 connector, Power out on EIAJ-04 connector  |
| <b>OneLINK Interface Dimensions</b>    | 1.72" (43.7mm) H x 8.375" (212.7mm) W x 6.00" (152.4mm) D  |
| <b>OneLINK EZIM Dimensions</b>         | 3.861" (98.07mm) H x 4.310" (109.47mm) W x 1.24" (31.5mm) D  |
| <b>OneLINK Interface Weight</b>        | 1.553 lbs. (703.1g)  |
| <b>OneLINK EZIM Weight:</b>            | 0.553 lbs. (249.5g)  |
| <b>Operating Temperature/Humidity</b>  | 0°C (32°F) to 40°C (104°F), 20% to 80% Relative Humidity   |
| <b>Storage Temperature</b>             | -20°C (-4°F) to +60°C (140°F)  |

**Notes:** Specifications and pricing are subject to change without prior notice or obligation.

**APPENDIX 1: CONNECTORS AND SIGNALS**

**OneLINK HDMI EZIM - RS-232 Control Port RJ-45**

| <b>PIN#</b> | <b>Signal</b>          |
|-------------|------------------------|
| 1)          | Unused                 |
| 2)          | Unused                 |
| 3)          | Unused                 |
| 4)          | IR GND                 |
| 5)          | IR (non-mod)           |
| 6)          | GND                    |
| 7)          | TX (to RX of camera)   |
| 8)          | RX (from TX of camera) |

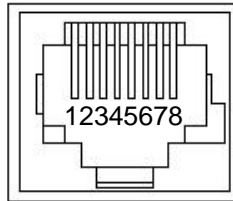

**OneLINK HDMI Interface - RS-232 Control Port (RJ-45)**

| <b>PIN#</b> | <b>Signal</b>              |
|-------------|----------------------------|
| 1)          | Unused                     |
| 2)          | Unused                     |
| 3)          | Unused                     |
| 4)          | Unused                     |
| 5)          | Unused                     |
| 6)          | GND                        |
| 7)          | RX (from TX of controller) |
| 8)          | TX (to RX of controller)   |

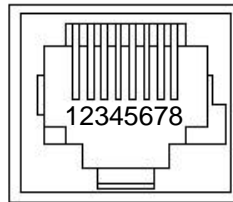

**OneLINK HDMI Interface - Ethernet Network Port (RJ-45)**

| <b>PIN#</b> | <b>Signal</b> |
|-------------|---------------|
| 1)          | TX+_D1        |
| 2)          | TX-_D1        |
| 3)          | RX+_D2        |
| 4)          | BI+_D3        |
| 5)          | BI-_D3        |
| 6)          | RX-_D2        |
| 7)          | BI+_D4        |
| 8)          | BI-_D4        |

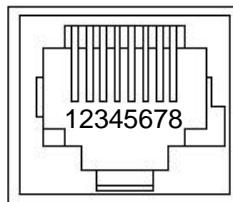

**OneLINK HDMI Interface - IR output on Euro style 3-pin:**

| <b>PIN#</b> | <b>Signal</b>    |
|-------------|------------------|
| 1)          | Modulated IR     |
| 2)          | Common Ground    |
| 3)          | Non-modulated IR |

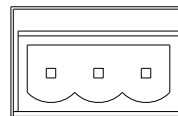

Not Used with the Cisco Precision 60 Camera

1 2 3



## COMPLIANCE AND CE DECLARATION OF CONFORMITY - ONELINK HDMI INTERFACE

Compliance testing was performed to the following regulations:

- **FCC Part 15** (15.107, 15.109), **Subpart B**
- **ICES-003, Issue 5: 2012**
- **EMC Directive 2004/108/EC**
- **EN 55022: December 2010**
- **EN 55024: November 2010**
- **KN22 2008 (CISPR 22: 2006)**
- **KN24 2008 (CISPR 24: 1997 + A1: 2000 + A2: 2002)**
- **IEC 60950-1:2005 (2nd Edition); Am 1:2009 + Am 2:2013**
- **EN 60950-1:2006 + A11:2009 + A1:2010 + A12:2011 + A2:2013**

- Class A
- Class A
- Class A
- Class A
- Class A
- Class A
- Class A
- Safety
- Safety



**OneLINK HDMI Interface**  
P/N: 998-1105-043



### FCC Part 15 Compliance

This equipment has been tested and found to comply with the limits for a Class A digital device, pursuant to Part 15, Subpart B, of the FCC Rules. These limits are designed to provide reasonable protection against harmful interference when the equipment is operated in a commercial environment. This equipment generates, uses, and can radiate radio frequency energy and, if not installed and used in accordance with the instruction manual, may cause harmful interference to radio communications. Operation of this equipment in a residential area is likely to cause harmful interference in which case the user will be required to correct the interference at his/her own expense.

Operation is subject to the following two conditions: (1) This device may not cause interference, and (2) This device must accept any interference including interference that may cause undesired operation of the device.

Changes or modifications not expressly approved by Vaddio can affect emission compliance and could void the user's authority to operate this equipment.



### ICES-003 Compliance

This digital apparatus does not exceed the Class A limits for radio noise emissions from digital apparatus set out in the Radio Interference Regulations of the Canadian Department of Communications.

Le présent appareil numérique n'émet pas de bruits radioélectriques dépassant les limites applicables aux appareils numériques de la classe A prescrites dans le Règlement sur le brouillage radioélectrique édicté par le ministère des Communications du Canada.



### European Compliance

This product has been evaluated for Electromagnetic Compatibility under the EMC Directive for Emissions and Immunity and meets the requirements for a Class A digital device. In a domestic environment this product may cause radio interference in which case the user may be required to take adequate measures.

#### Standard(s) To Which Conformity Is Declared:

##### EMC Directive 2004/108/EC

##### EN 55022: December 2010

##### EN 55024: November 2010

- EN 61000-4-2: 1995 + Amendments A1: 1998 + A2: 2001
- EN 61000-4-3: 2006 + A1: 2008
- EN 61000-4-4: 2004 + Corrigendum 2006
- EN 61000-4-5: 2006
- EN 61000-4-6: 2009
- EN 61000-4-8: 2010
- EN 61000-4-11: 2004

##### KN22 2008 (CISPR 22: 2006)

##### KN24 2008 (CISPR 24: 1997 + A1: 2000 + A2: 2002)

- EN 61000-4-2
- EN 61000-4-3
- EN 61000-4-4
- EN 61000-4-5
- EN 61000-4-6
- EN 61000-4-8
- EN 61000-4-11

##### IEC 60950-1:2005 (2nd Edition); Am 1:2009 + Am 2:2013

##### EN 60950-1:2006 + A11:2009 + A1:2010 + A12:2011 + A2:2013

##### Conducted and Radiated Emissions

- Immunity
- Electrostatic Discharge
- Radiated Immunity
- Electrical Fast Transients
- Surge Immunity
- Conducted Immunity
- Power Frequency Magnetic Field
- Voltage Dips, Interrupts and Fluctuations
- Conducted and Radiated Emissions
- IT Immunity Characteristics
- Electrostatic Discharge
- Radiated Immunity
- Electrical Fast Transients
- Surge Immunity
- Conducted Immunity
- Power Frequency Magnetic Field
- Voltage Dips, Interrupts and Fluctuations
- Safety
- Safety





## COMPLIANCE AND CE DECLARATION OF CONFORMITY - ONELINK HDMI EZIM

Compliance testing was performed to the following regulations:

- **FCC Part 15** (15.107, 15.109), **Subpart B**
- **ICES-003, Issue 5: 2012**
- **EMC Directive 2004/108/EC**
- **EN 55022: December 2010**
- **EN 55024: November 2010**
- **KN22 2008 (CISPR 22: 2006)**
- **KN24 2008 (CISPR 24: 1997 + A1: 2000 + A2: 2002)**
- **IEC 60950-1:2005 (2nd Edition); Am 1:2009 + Am 2:2013**
- **EN 60950-1:2006 + A11:2009 + A1:2010 + A12:2011 + A2:2013**

- Class A
- Class A
- Class A
- Class A
- Class A
- Class A
- Class A
- Class A
- Safety
- Safety



**OneLINK HDMI EZIM**  
P/N: 998-6700-043



### FCC Part 15 Compliance

This equipment has been tested and found to comply with the limits for a Class A digital device, pursuant to Part 15, Subpart B, of the FCC Rules. These limits are designed to provide reasonable protection against harmful interference when the equipment is operated in a commercial environment. This equipment generates, uses, and can radiate radio frequency energy and, if not installed and used in accordance with the instruction manual, may cause harmful interference to radio communications. Operation of this equipment in a residential area is likely to cause harmful interference in which case the user will be required to correct the interference at his/her own expense.

Operation is subject to the following two conditions: (1) This device may not cause interference, and (2) This device must accept any interference including interference that may cause undesired operation of the device.

Changes or modifications not expressly approved by Vaddio can affect emission compliance and could void the user's authority to operate this equipment.



### ICES-003 Compliance

This digital apparatus does not exceed the Class A limits for radio noise emissions from digital apparatus set out in the Radio Interference Regulations of the Canadian Department of Communications.

Le présent appareil numérique n'émet pas de bruits radioélectriques dépassant les limites applicables aux appareils numériques de la classe A prescrites dans le Règlement sur le brouillage radioélectrique édicté par le ministère des Communications du Canada.



### European Compliance

This product has been evaluated for Electromagnetic Compatibility under the EMC Directive for Emissions and Immunity and meets the requirements for a Class A digital device. In a domestic environment this product may cause radio interference in which case the user may be required to take adequate measures.

#### Standard(s) To Which Conformity Is Declared:

##### EMC Directive 2004/108/EC

##### EN 55022: December 2010

##### EN 55024: November 2010

- EN 61000-4-2: 1995 + Amendments A1: 1998 + A2: 2001
- EN 61000-4-3: 2006 + A1: 2008
- EN 61000-4-4: 2004 + Corrigendum 2006
- EN 61000-4-5: 2006
- EN 61000-4-6: 2009
- EN 61000-4-8: 2010
- EN 61000-4-11: 2004

##### KN22 2008 (CISPR 22: 2006)

##### KN24 2008 (CISPR 24: 1997 + A1: 2000 + A2: 2002)

- EN 61000-4-2
- EN 61000-4-3
- EN 61000-4-4
- EN 61000-4-5
- EN 61000-4-6
- EN 61000-4-8
- EN 61000-4-11

##### IEC 60950-1:2005 (2nd Edition); Am 1:2009 + Am 2:2013

##### EN 60950-1:2006 + A11:2009 + A1:2010 + A12:2011 + A2:2013

- Conducted and Radiated Emissions
- Immunity
- Electrostatic Discharge
- Radiated Immunity
- Electrical Fast Transients
- Surge Immunity
- Conducted Immunity
- Power Frequency Magnetic Field
- Voltage Dips, Interrupts and Fluctuations
- Conducted and Radiated Emissions
- IT Immunity Characteristics
- Electrostatic Discharge
- Radiated Immunity
- Electrical Fast Transients
- Surge Immunity
- Conducted Immunity
- Power Frequency Magnetic Field
- Voltage Dips, Interrupts and Fluctuations
- Safety
- Safety

## WARRANTY INFORMATION

(See Vaddio Warranty, Service and Return Policies posted on [vaddio.com](http://vaddio.com) for complete details):

**Hardware\* Warranty:** Two (2) year limited warranty on all parts and labor for Vaddio manufactured products. Vaddio warrants its manufactured products against defects in materials and workmanship for a period of two years from the day of purchase, to the original purchaser, if Vaddio receives notice of such defects during the warranty. Vaddio, at its option, will repair or replace products that prove to be defective. Vaddio manufactures its hardware products from parts and components that are new or equivalent to new in accordance with industry standard practices.

**Exclusions:** The above warranty shall not apply to defects resulting from improper or inadequate maintenance by the customer, customers applied software or interfacing, unauthorized modifications or misuse, mishandling, operation outside the normal environmental specifications for the product, use of the incorrect power supply, modified power supply or improper site operation and maintenance. OEM and Special Order products manufactured by other companies are excluded and are covered by the manufacturer's warranty.

**Vaddio Customer Service:** Vaddio will test, repair, or replace the product or products without charge if the unit is under warranty. If the product is out of warranty, Vaddio will test then repair the product or products. The cost of parts and labor charge will be estimated by a technician and confirmed by the customer prior to repair. All components must be returned for testing as a complete unit. Vaddio will not accept responsibility for shipment after it has left the premises.

**Vaddio Technical Support:** Vaddio technicians will determine and discuss with the customer the criteria for repair costs and/or replacement. Vaddio Technical Support can be contacted through one of the following resources: e-mail support at [support@vaddio.com](mailto:support@vaddio.com) or online at [vaddio.com](http://vaddio.com).

**Return Material Authorization (RMA) Number:** Before returning a product for repair or replacement request an RMA from Vaddio's technical support. Provide the technician with a return phone number, e-mail address, shipping address, product serial numbers and original purchase order number. Describe the reason for repairs or returns as well as the date of purchase. See the General RMA Terms and Procedures section for more information. RMA's are valid for 30 days and will be issued to Vaddio dealers only. End users must return products through Vaddio dealers. Include the assigned RMA number in all correspondence with Vaddio. Write the assigned RMA number clearly on the shipping label of the box when returning the product. All products returned for credit are subject to a restocking charge without exception. Special Order product are not returnable.

**Voided Warranty:** The warranty does not apply if the original serial number has been removed or if the product has been disassembled or damaged through misuse, accident, modifications, use of incorrect power supply, use of a modified power supply or unauthorized repair.

**Shipping and Handling:** Vaddio will not pay for inbound shipping transportation or insurance charges or accept any responsibility for laws and ordinances from inbound transit. Vaddio will pay for outbound shipping, transportation, and insurance charges for all items under warranty but will not assume responsibility for loss and/or damage by the outbound freight carrier. If the return shipment appears damaged, retain the original boxes and packing material for inspection by the carrier. **Contact your carrier immediately.**

**Products not under Warranty:** Payment arrangements are required before outbound shipment for all out of warranty products.

### Other General Information:

#### Care and Cleaning

Do not attempt to take this product apart at any time. There are no user-serviceable components inside.

- Do not spill liquids in the product
- Keep this device away from food and liquid
- For smears or smudges on the product, wipe with a clean, soft cloth
- Do not use any abrasive chemicals.

#### Operating and Storage Conditions:

Do not operate or store the device under the following conditions:

- Temperatures above 40°C (104°F) or temperatures below 0°C (32°F)
- High humidity, condensing or wet environments
- In inclement weather or in swimming pools
- Dry environments with an excess of static discharge
- Under severe vibration
- In, above or below inclement weather
- Haunted locations (ghosting video may result)
- In outer space (without star ship)





Toll Free: 800-572-2011 ▪ Phone: 763-971-4400 ▪ FAX: 763-971-4464  
[www.vaddio.com](http://www.vaddio.com)