

# OASIS™ & OASIS™ MINI Table Trough Installation Sheet

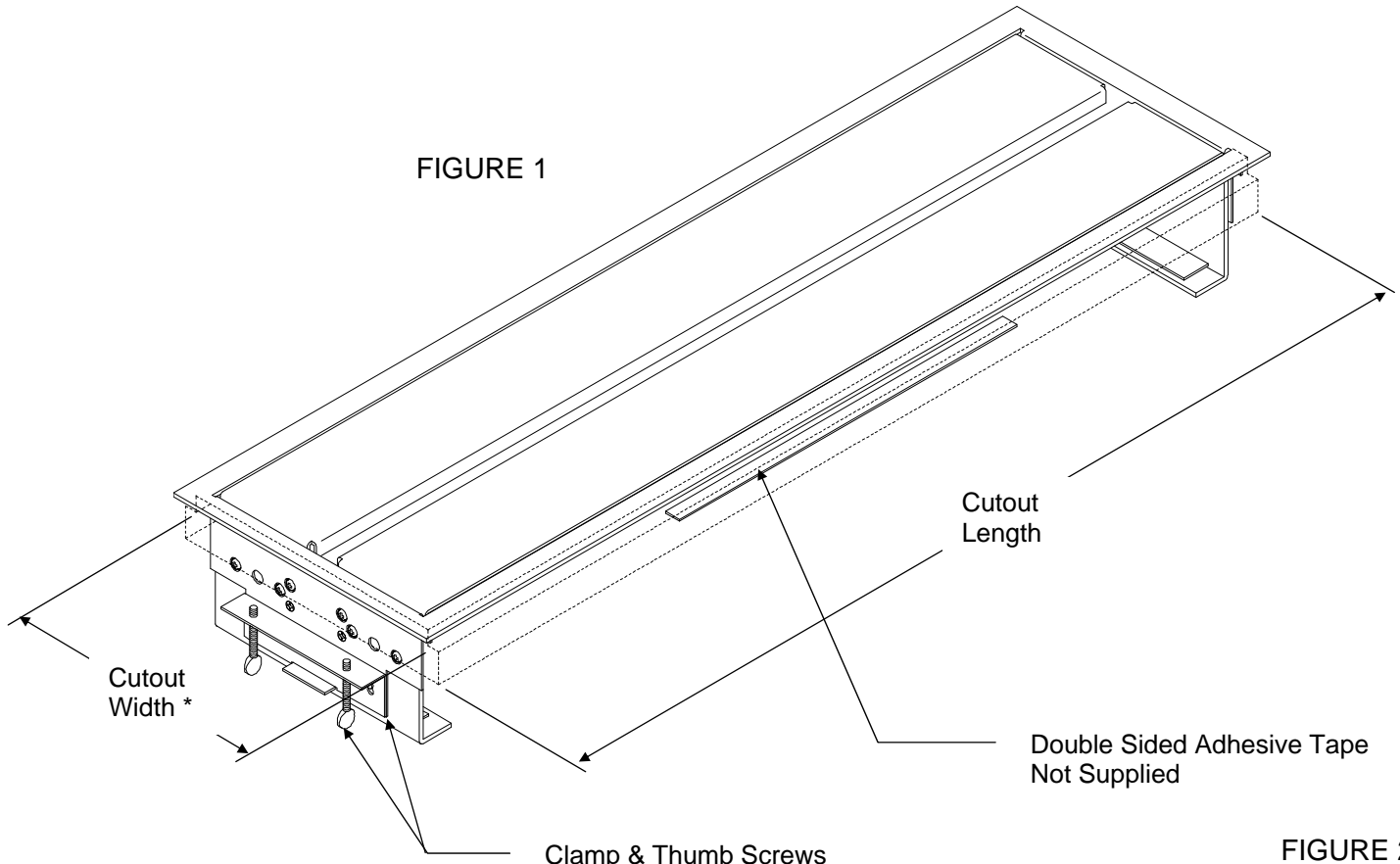

CUTOUT SIZES		
	Oasis	Oasis Mini
Cutout Width*	8.25	8.25
Cutout Length	29.12	14.12

\* See Cutout Detail for undercuts required for door clearance.

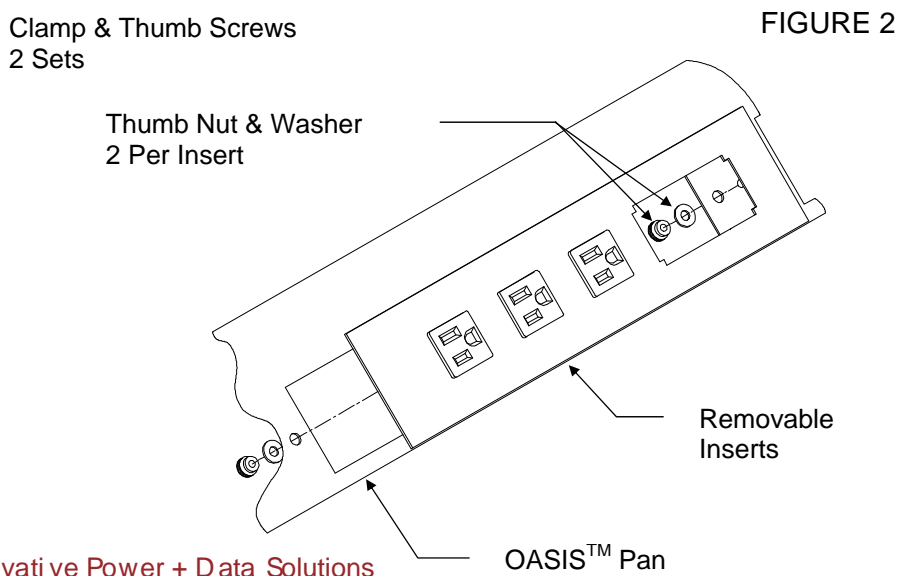

Innovative Power + Data Solutions

ECA • 10 Mountain View Drive • Shelton, CT 06484 • Phone: 1-800-521-3175 • Fax: 203-924-6687

[www.electri-cable.com](http://www.electri-cable.com)

### CUTOUT DETAIL

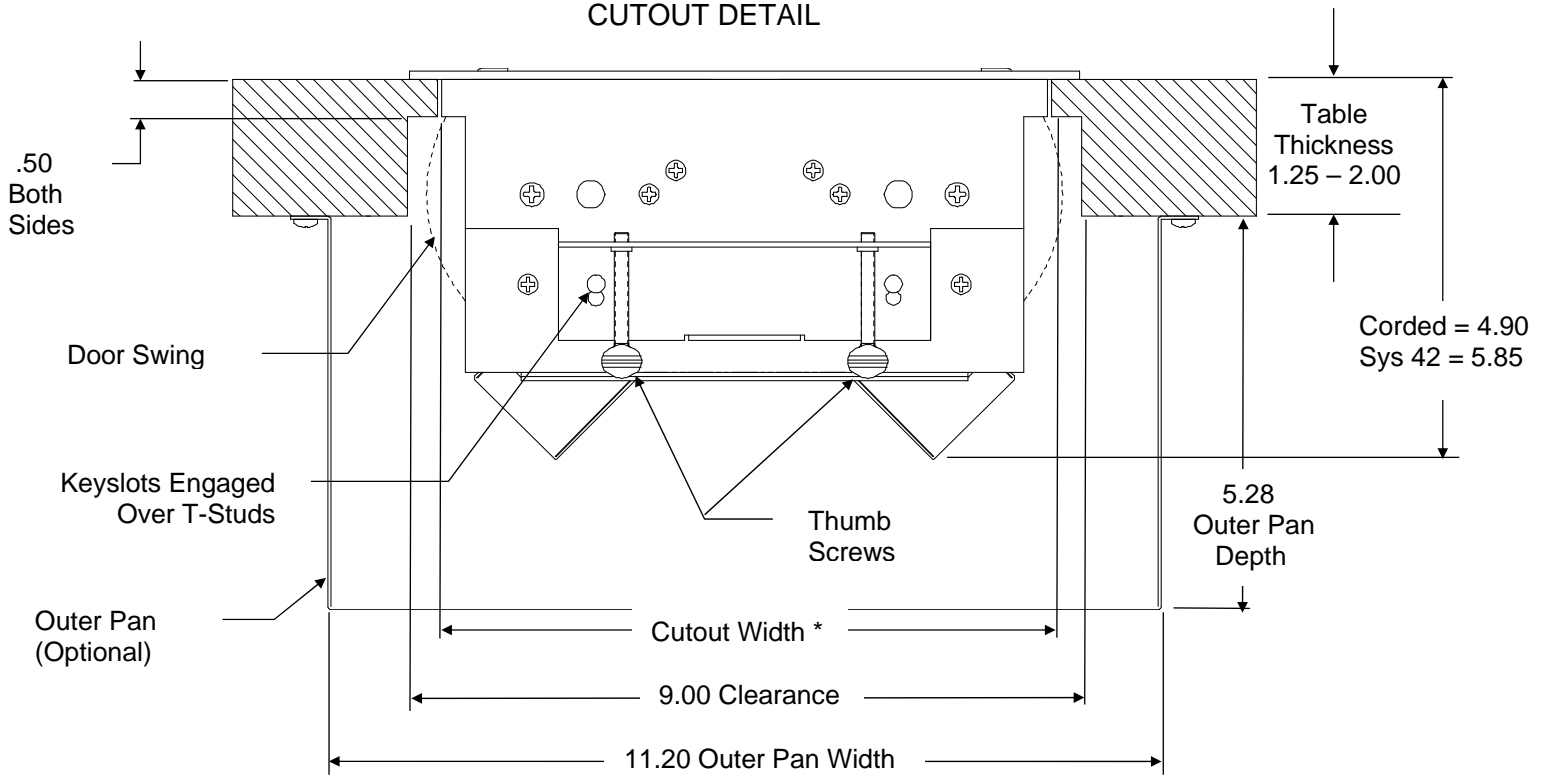

### Installation Instructions

1. Cutout table as required (see Figure 1, Cutout Sizes & Cutout Detail)
2. Insert OASIS™ into cutout from above and clamp into position using Clamps & thumb Screws provided. Note: Keyslots in clamps engage over T-Studs in OASIS™ and thumb screws tighten against underside of table surface. (double sided tape may be required to prevent side of Bezel from bowing when in table).
3. Check for smooth operation of doors and adjust in cutout if required.
4. OASIS™ Inserts have been installed at the factory but may be repositioned in the field if desired. To reposition OASIS™ Inserts remove thumb nuts & washers from rear and reposition as needed (see Figure 2).
5. Connect all power & data cabling as needed and check for proper operation.
6. Attach Outer Pan (optional) to underside of table as shown in Cutout Detail.

Innovative Power + Data Solutions

ECA • 10 Mountain View Drive • Shelton, CT 06484 • Phone: 1-800-521-3175 • Fax: 203-924-6687

[www.electri-cable.com](http://www.electri-cable.com)

Recycled Content Information 				
	Oasis A	Oasis B	Oasis A Powder Coat	Oasis B Powder Coat
Post-Consumer Content	24.30%	23.50%	24.30%	23.60%
Pre-Consumer Content	7.80%	7.50%	6.10%	5.90%
Total % qualifying toward LEED®	28.20%	27.20%	27.30%	26.50%

Recycled Content Information 		
	Oasis Mini A/B	Oasis Mini A/B Powder Coat
Post-Consumer Content	37.20%	26.20%
Pre-Consumer Content	5.10%	6.50%
Total % qualifying toward LEED®	39.70%	29.40%

**Innovative Power + Data Solutions**

ECA • 10 Mountain View Drive • Shelton, CT 06484 • Phone: 1-800-521-3175 • Fax: 203-924-6687  
[www.electri-cable.com](http://www.electri-cable.com)