

### Overview

The HPX-P200 Hydraport Power Outlet Module (FG551-xx) is designed to be used in conjunction with the HPX-1600 Hydraport Base Assembly. See specifications for module requirements. For more information on the HPX-1600, refer to [www.amx.com](http://www.amx.com).

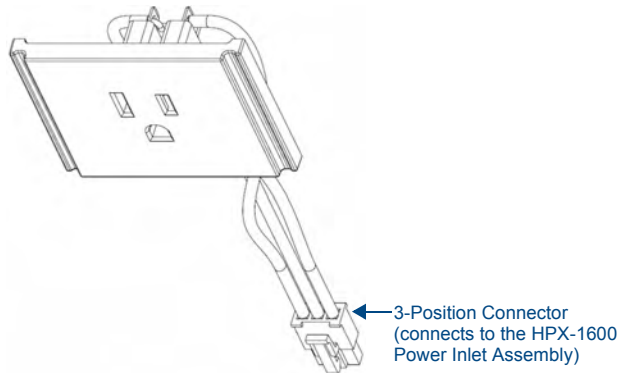

**FIG. 1** HPX-P200-xx Hydraport Power Outlet Module (HPX-P200-US shown)

The HPX-P200 Power Outlet Assembly provides user accessible AC "Mains" Power to the front panel of the Hydraport System.

**Note:** The Hydraport System limits the total available current for all Power Outlet Modules to 10 Amps total.

### Product Specifications

HPX-P200-XX Specifications	
Models Available:	<ul style="list-style-type: none"> <li>• HPX-P200-US - North America / Japan (FG-551-01)</li> <li>• HPX-P200-EU - European Union (FG-551-11)</li> <li>• HPX-P200-UK - United Kingdom (FG-551-21)</li> <li>• HPX-P200-AU - Australia / China (FG-551-31)</li> <li>• HPX-P250-IN - India (FG551-41)</li> </ul>
<b>Dimensions (HWD):</b>	
• HPX-P200-US	50mm x 52mm x 36mm (1.96" x 2.05" x 1.41")
• HPX-P200-EU	50mm x 52mm x 38mm (1.96" x 2.05" x 1.50")
• HPX-P200-UK	67mm x 52mm x 27mm (2.63" x 2.05" x 1.06")
• HPX-P200-AU	50mm x 52mm x 30mm (1.96" x 2.05" x 1.18")
• HPX-P250-IN	67mm x 52mm x 27mm (2.63" x 2.05" x 1.06")
Cable Length (All)	300mm (12.0in)
<b>Weight:</b>	
• HPX-P200-US	60g (2.12 oz.) -
• HPX-P200-EU	69g (2.43 oz.)
• HPX-P200-UK	74g (2.61 oz.)
• HPX-P200-AU	60g (2.12 oz.)
• HPX-P250-IN	70g (2.47 oz.)
Enclosure:	Matt black finished face plate (Polycarbonate plastic).
Rear Connections:	Three position plug-in connector for use with HPX-1600 Hydraport Base Assembly.
Compatibility:	<ul style="list-style-type: none"> <li>• HPX-1600 Hydraport Base Assembly</li> <li>• HPX-PAK-I, Hydraport Power Accessory Kit w/ no power cord (FG559-32)</li> </ul>
Included Accessories:	Installation Guide

### Installation

**ATTENTION!** Only a professional, AMX-qualified installer should perform this installation. Installation must conform to all local codes. This product may not be installed by the end-user.

**ATTENTION!** If one or more HPX-200-xx Power Outlet Module is to be installed into a Hydraport Base Assembly (HPX-1600-xx) along with one or more Low-Voltage, Secondary Circuit (LVSC) Module, they must be separated by a High Voltage Isolator (HPX-PA-HVI, FG 559-33). Failure to install the High Voltage Isolator (HPX-PA-HVI) properly will void product safety certifications.

See the Installation Guide provided with the High Voltage Isolator (HPX-PA-HVI) for detailed Installation Instructions.

**CAUTION!** Ensure that the AC Power cord is disconnected from IEC C-14 power inlet connector on the Hydraport Base Assembly, or is disconnected from the AC Mains Power Branch Circuit, prior to disassembly of the Hydraport Base assembly or installation of the HPX-P200-XX Power Outlet Module (see FIG. 2).

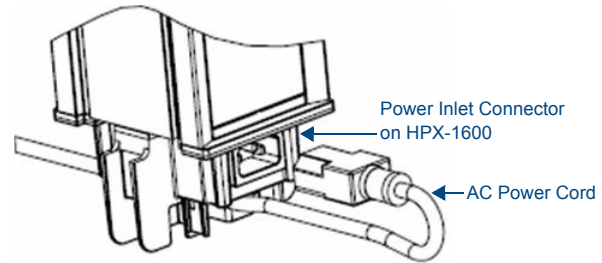

**FIG. 2** HPX-1600 - Power Inlet Cord Removed

### Step 1 - Connect the HPX-P200 to the HPX-1600 Power Inlet Assembly

Plug the 3-Position Connector from the Power Outlet Module into the Power Inlet Assembly located in the bottom cover of the HPX-1600 Base Assembly (FIG. 3).

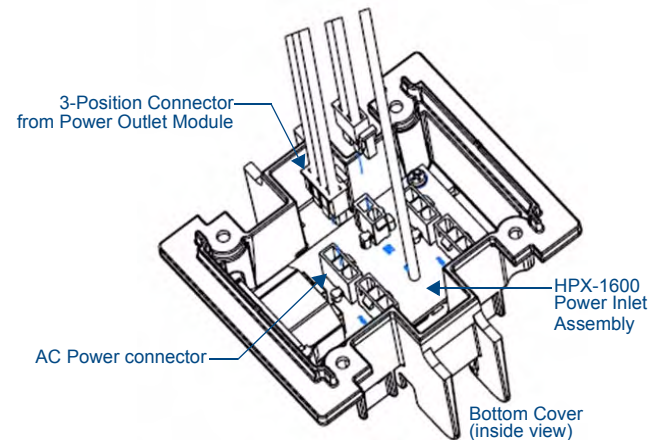

**FIG. 3** HPX-1600 Bottom Cover - Connect HPX-P200 to Power Inlet Assembly

### Step 2 - Insert the HPX-P200 Into the HPX-1600 Chassis

Insert the HPX-P200-XX Power Outlet Module into the main chassis of the HPX-1600 Base Assembly. Note the position of module interlock tab: this tab should face towards the bottom of the HPX-1600 Base assembly when installed in its mounted position (FIG. 4).

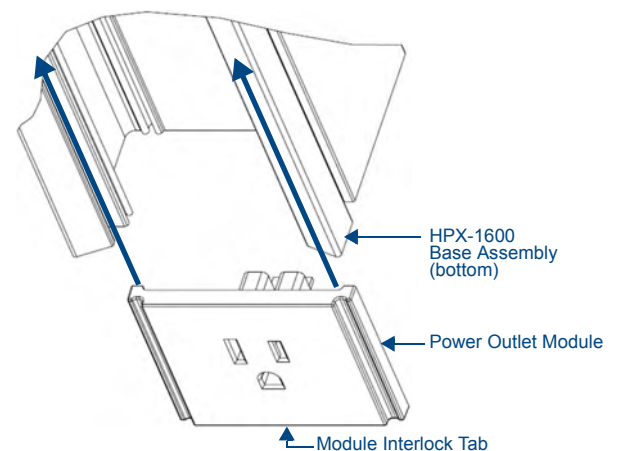

**FIG. 4** Inserting the Power Module into the HPX-1600 Chassis

### Step 3 - Install the 10 Amp Circuit Breaker(s)

One (for US) or two (for UK, EU, AU, IN) Circuit Breaker Modules are required for the HPX-P200-XX Power Outlet Module to be functional.

These 10 Amp circuit breakers for the Hydraport System prevent power overload and complete the AC Power Circuit.

Position the Circuit breaker module(s) included in the HPX-1600 in the main chassis of the Hydraport base assembly such that it resides just below the mounting surface in which the Hydraport system is installed (FIG. 5).

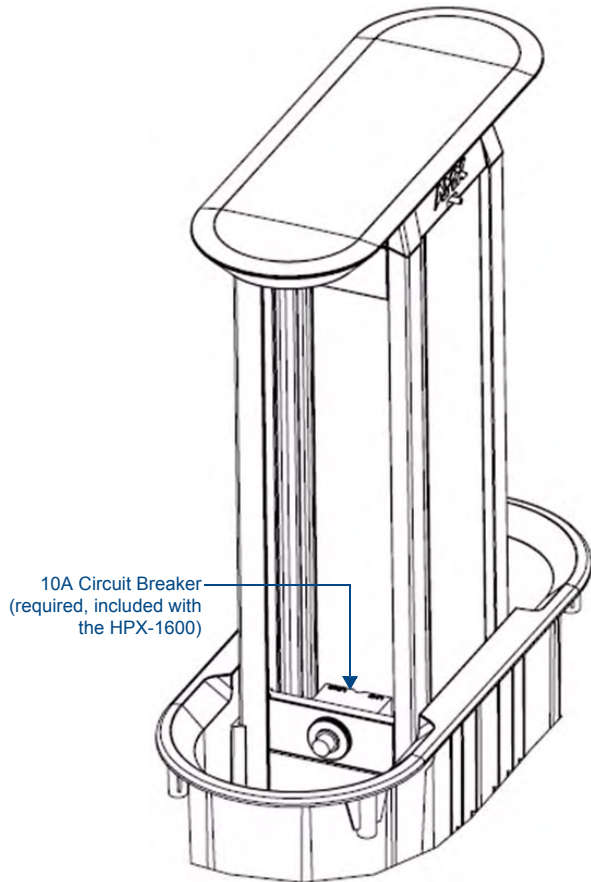

**FIG. 5** 10A Circuit Breaker Module positioned just below mounting surface level

