

Overview

The HPX-CPT200 Hydraport Cable Passthrough Module (**FG552-41**) is designed to be used in conjunction with the HPX-1600 Hydraport Base Assembly.

The HPX-CPT200 Cable Pass-through Module provides a means to capture retractable, pre-terminated cables for video, audio and network connectivity on the face of the Hydraport system.

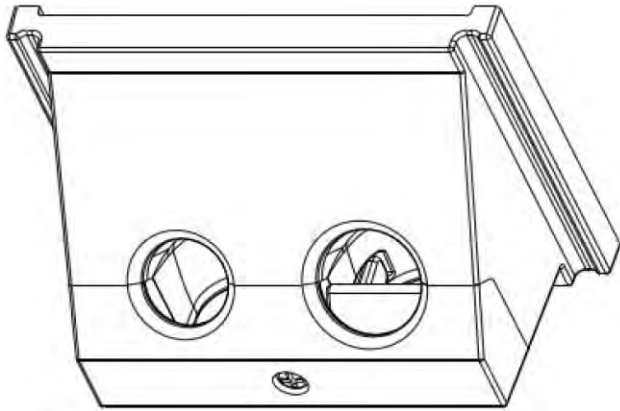

FIG. 1 HPX-CPT200 Hydraport Cable Pass-through Module

- See specifications for module requirements.
- For more information on the HPX-1600, refer to www.amx.com.

Product Specifications

HPX-CPT200 Specifications	
Dimensions (HWD)	50mm x 52mm x 37mm (2.97" x 2.05" x 1.46")
Weight:	27g (1.3 oz.)
Enclosure:	Matt black finished plastic construction (PC-ABS Plastic)
Front Connections:	Provided by cables installed
Rear Connections:	Provided by cables installed
Compatibility:	<ul style="list-style-type: none"> • HPX-1600 Hydraport Base Assembly • DVI Cables • HDMI Cables • D-Sub HD-15 RGBHV (VGA) Cables • 3.5mm Jack style Stereo Audio Cables • Cat 5 Ethernet Cables
Included Accessories:	Installation Guide

Installation

Attention! Only a professional, AMX-qualified installer should perform this installation. Installation must conform to all local codes. This product may not be installed by the end-user.

Tools Required

- Wire cutting pliers
- Phillips Screw Driver

CAUTION! Ensure that the AC Power cord is disconnected from the Mains Power Source or from the IEC C-14 power inlet connector on the Hydraport Base Assembly prior to disassembly of the Hydraport Base assembly or installation of the HPX-C5400-VGA+A Module (see FIG. 2).

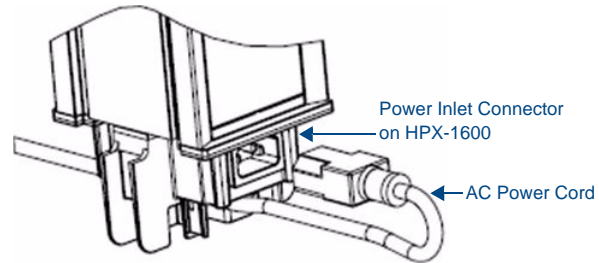

FIG. 2 HPX-1600 - Power Inlet Cord Removed

Step 1 - Insert the Module Into the HPX-1600 Chassis

Insert the module into the main chassis of the HPX-1600 Base Assembly. Note the position of module interlock tab: this tab should face towards the bottom of the HPX-1600 Base assembly when installed in its mounted position (FIG. 3).

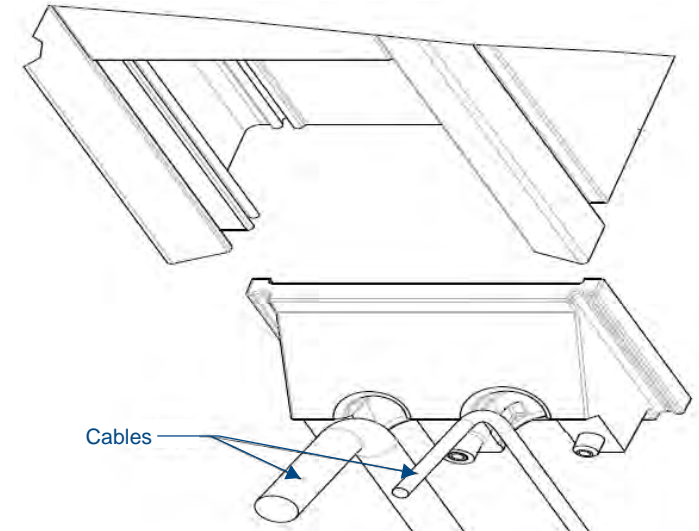

FIG. 3 Inserting the Module

Note: For installations for which the far end of the cable is not accessible either because the cable has been run under carpet, in a conduit or structure, or is otherwise fixed, the cable must be placed through the retaining ring (note the orientation of the retaining ring) then through the mounting surface from bottom to top, then captured by the module.

Step 2 - Install the Bottom Cover On the HPX-1600

Note: Install any remaining modules into the Hydraport Base Assembly before installing the Bottom Cover on the HPX-1600.

1. Install the bottom cover (including the Power Inlet Assembly) onto the bottom of the main frame of the Hydraport Base Assembly.
The cables from the other modules (except AC Power Outlets) will exit the bottom of the Hydraport Base Assembly through one of four square passages on either side of the bottom cover.
2. After the bottom cover is secured using four screws, secure the cables to the corresponding tab near each opening using a small cable tie (FIG. 4).

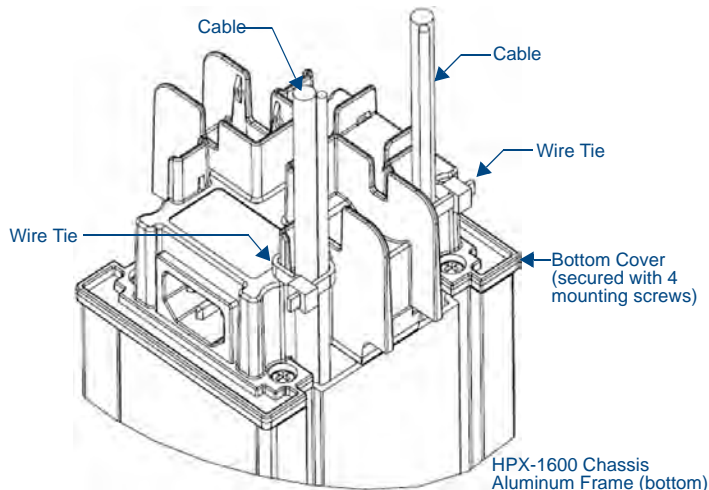

FIG. 4 Bottom Cover - Installed With Cables Exiting and Secured

Step 3 - Capture the Cables in the Module

1. With the HPX-CPT200 Module installed in the HPX-1600, remove the single #2 Phillips screw from front of the module.
2. Remove the front portion of the Module and the reducer.
3. Use the reducer to accommodate small cables such as Audio cables or CAT 5 Cables.
4. Place the cable(s) in the appropriate recess and reinstall the front portion of the module and reducer (if required).
5. Secure with the #2 Phillips screw (FIG. 5).

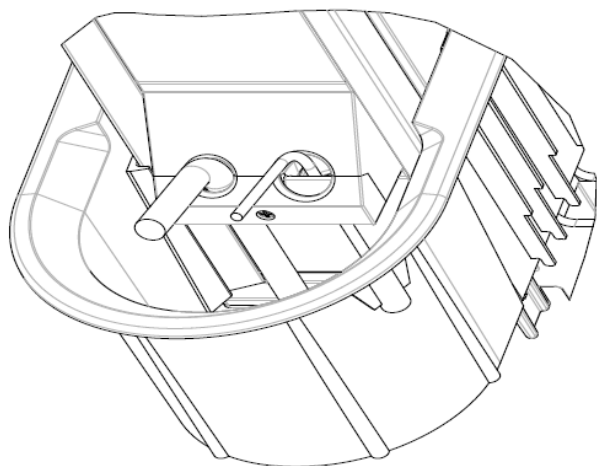

FIG. 5 Capture the Cables

Step 4 - Provide a Service Loop

Ensure there is sufficient cable length to provide a service loop for the cable after the module is installed into the Hydraport Base Assembly (FIG. 6).

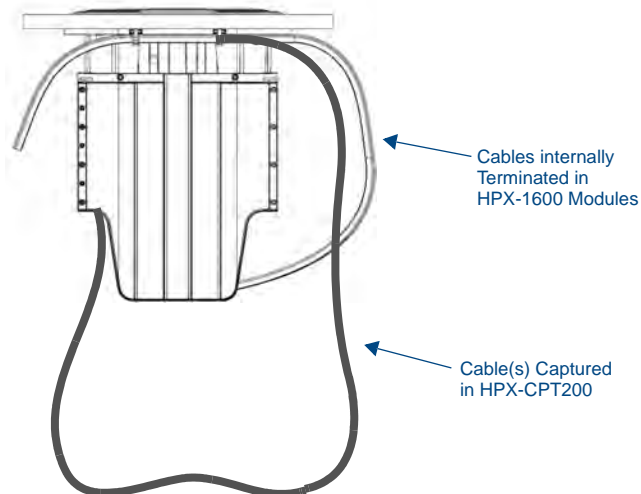

FIG. 6 Secured Service Loop

Note that the Hydraport Base Assembly travels up and down approximately 228.6 mm (9") during operation.

Unlike cables terminated internally to other HPX-1600 modules, the cable(s) captured in the HPX-CPT200 Cable Pass-through Modules are intended to be pulled outward by the user in order to connect directly to the user's equipment (Laptop, etc).

Note: The service loop must accommodate both of these motions and may require a longer service loop prior to securing the cable to the Hydraport Base Assembly.

For more detailed information, please refer to the HPX-1600-XX Hydraport Base Assembly Instruction Manual.

