

Overview

The HPX-C5400-CS+A Composite Video + Stereo UPX Module (FG552-50-BL-K) is designed to be used in conjunction with the HPX-1600 Hydraport Base Assembly. See specifications for module requirements. For more information on the HPX-1600, refer to www.amx.com.

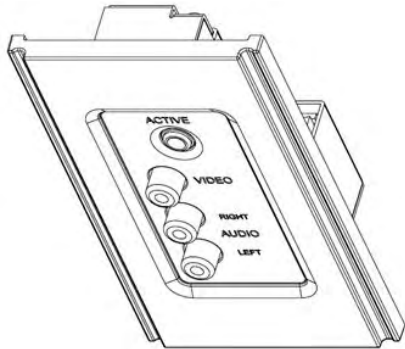

FIG. 1 HPX-C5400-CS+A Component Video + Stereo UPX Module

The HPX-C5400-CS+A Composite + Stereo UPX Module provides user-accessible RCA Composite Video and Stereo connections on the face of the Hydraport system. The HPX-C5400-CS+A Composite + Stereo UPX Module provides connection from the user's source equipment to a remote client such as projector, monitor, display or stereo sound system over CAT 5 cable using AMX's proprietary UPX system.

Product Specifications

HPX-C5400-CS+A Specifications	
Dimensions (HWD)	100mm x 52mm x 37mm (3.94" x 2.05" x 1.46")
Weight:	101g (3.57 oz.)
Enclosure:	Matt black finished face plate (ABS Plastic), sheet metal back box (aluminum).
Front Connections:	RCA style connections for: <ul style="list-style-type: none"> • Composite Video • Left Audio • Right Audio
Rear Connections:	RJ45 (CAT 5) receptacle
Compatibility:	<ul style="list-style-type: none"> • HPX-1600 Hydraport Base Assembly • AVX-400 CAT5 Switcher • "RCA Style Composite Video Source • 2 RCA style Stereo Audio Source
Included Accessories:	Installation Guide

Installation

Attention! Only a professional, AMX-qualified installer should perform this installation. Installation must conform to all local codes. This product may not be installed by the end-user.

Tools Required

- Wire cutting pliers
- Phillips Screw Driver (to access Hydraport Base Assembly)

CAUTION! Ensure that the AC Power cord is disconnected from IEC C-14 power inlet connector on the Hydraport Base Assembly prior to disassembly of the Hydraport Base assembly or installation of the HPX-C5400-CS+A Module (see FIG. 2).

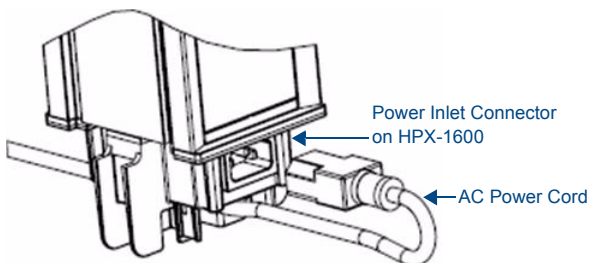

FIG. 2 HPX-1600 - Power Inlet Cord Removed

Step 1 - Backside Termination

Before installing the module into the Hydraport Base Assembly, the backside terminations of the module must be completed. This backside termination involves simply plugging in the CAT 5 cable into the RJ45 receptacle on the back of the HPX-C5400-CS+A Module (FIG. 3).

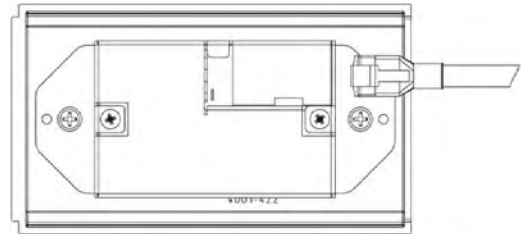

FIG. 3 Backside Termination

Note that for terminations for which the far end of the cable is not accessible either because the cable has been run under carpet, in a conduit or structure, or is otherwise fixed, the cable must be placed through the retaining ring (note the orientation of the retaining ring) then through the mounting surface from bottom to top, then to the module - *before the module is placed into the base assembly* (FIG. 4).

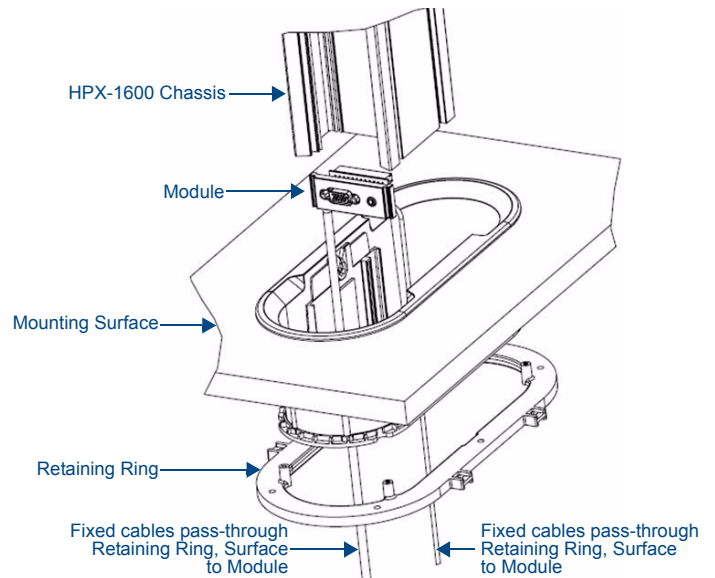

FIG. 4 Fixed Cable Passing Through Ring, Table and Into the HPX-1600 Chassis

Step 2 - Provide a Service Loop

Ensure there is sufficient cable length to provide a service loop for the cable after the module is installed into the Hydraport Base Assembly (FIG. 5).

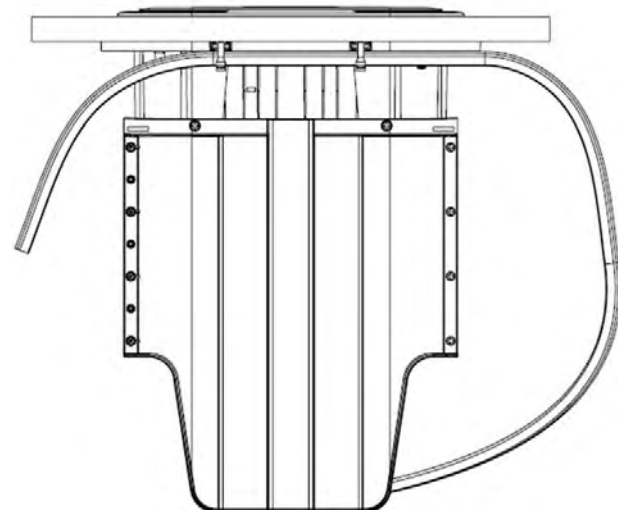

FIG. 5 Secured Service Loop

Note that the Hydraport Base Assembly travels up and down approximately 228.6 mm (9") during operation.

The service loop must accommodate this motion and provide for securing the cable to the Hydraport Base Assembly for strain relief.

For more detailed information, please refer to the HPX-1600-XX Hydraport Base Assembly Instruction Manual.

Step 3 - Insert the Module Into the HPX-1600 Chassis

Insert the module into the main chassis of the HPX-1600 Base Assembly.

Note the position of module interlock tab: this tab should face towards the bottom of the HPX-1600 Base assembly when installed in its mounted position (FIG. 6).

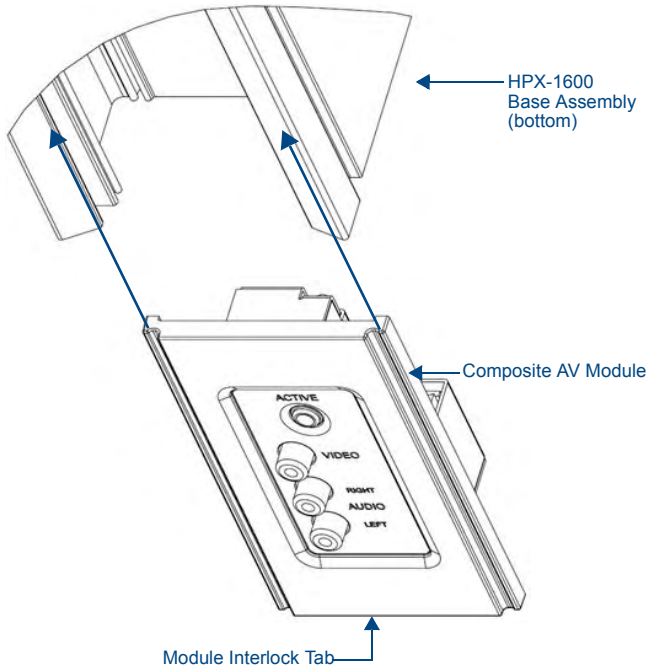

FIG. 6 Inserting the Composite AV Module into the HPX-1600 Chassis

Step 4 - Install the Bottom Cover On the HPX-1600

Note: Install any remaining modules into the Hydraport Base Assembly before installing the Bottom Cover on the HPX-1600.

1. Install the bottom cover (including the Power Inlet Assembly) onto the bottom of the main frame of the Hydraport Base Assembly.

The cables from the HPX-C5400-CS+A Module as well as all other modules (except AC Power Outlets) will exit the bottom of the Hydraport Base Assembly through one of four square passages on either side of the bottom cover.

2. After the bottom cover is secured using four screws, secure the cables to the corresponding tab near each opening using a small cable tie (FIG. 7).

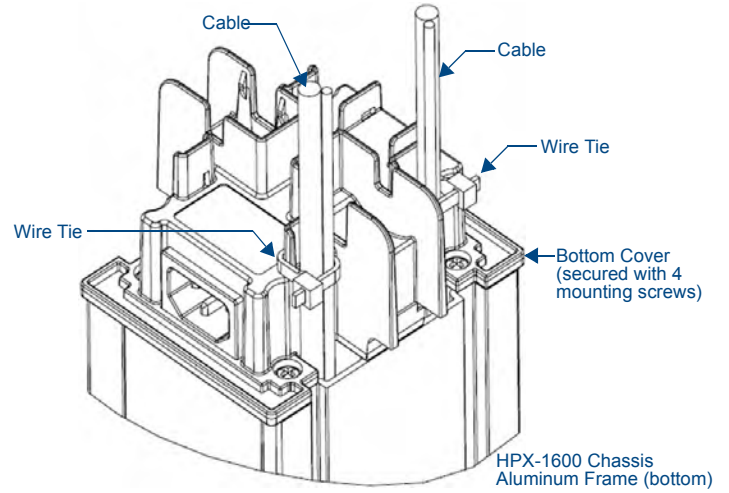

FIG. 7 Bottom Cover - Installed With Cables Exiting and Secured

