

## GANG DIVIDER ASSEMBLY

DIVIDER HOLDER **MUST** BE ORIENTED AS SHOWN WHEN ATTACHING TO DIVIDERS, IN ORDER TO PROPERLY ASSEMBLE BOX INTERIOR.

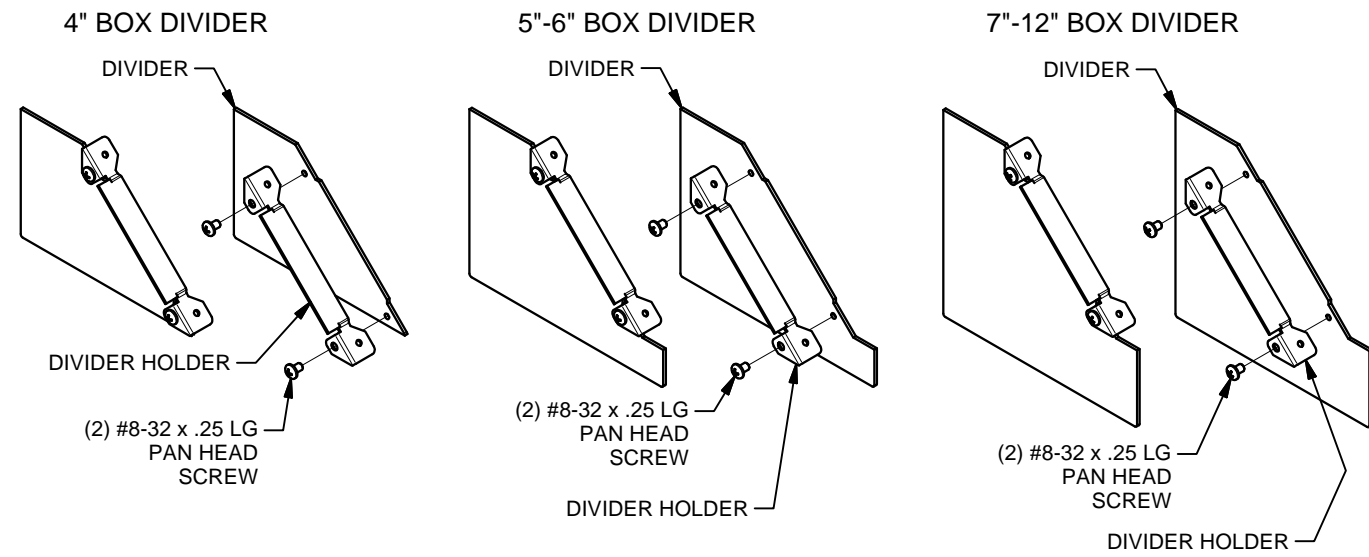

\* DIVIDER ASSEMBLY FOR 5" & 7" BOXES  
POSITION DIVIDER ASSEMBLY IN BOX **BEFORE** INSTALLING GANG PLATE ASSEMBLY. SECURE DIVIDER ASSEMBLY TO GANG PLATE ASSEMBLY WITH SCREWS AS NOTED.

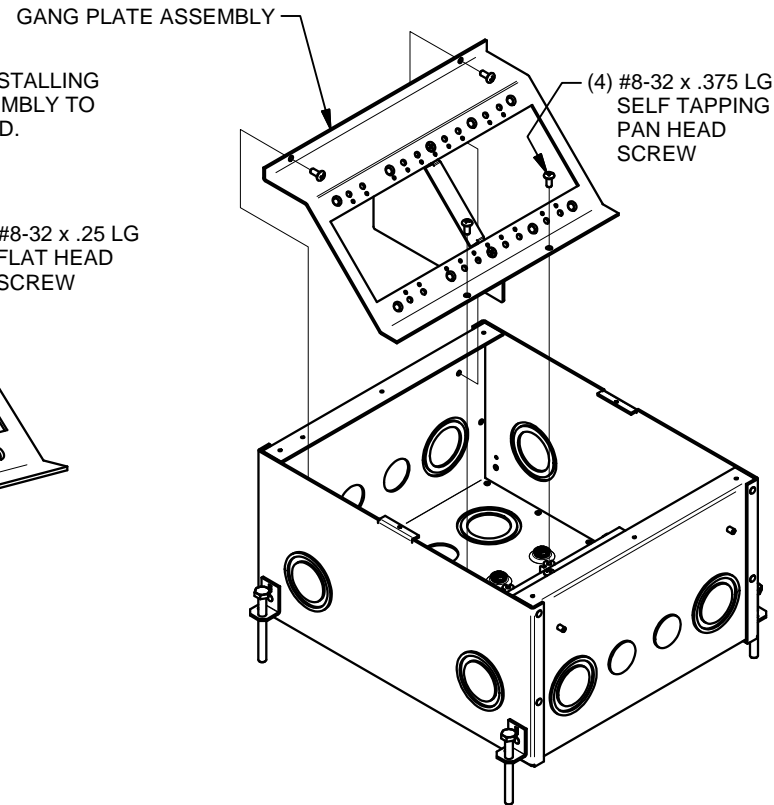
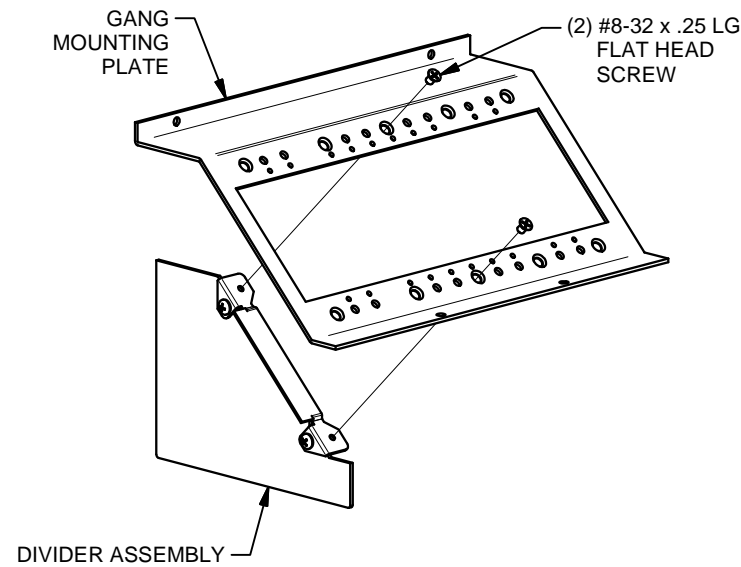

## INSTALLING ELECTRONIC COMPONENTS

PULL WIRES AND CABLES TO BOX AS NECESSARY (REMOVAL OF GANG MOUNTING BRACKETS MAY BE REQUIRED). TERMINATE WIRES AND CABLES TO ELECTRONIC COMPONENTS, AND INSTALL ELECTRONIC COMPONENTS ONTO GANG MOUNTING BRACKETS. REINSTALL TEMPORARY COVER IF FINISHED COVER IS TO BE INSTALLED AT A LATER DATE.

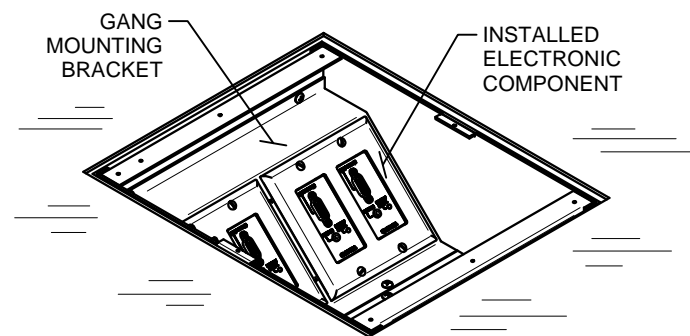

# FSR FL-500P INSTALLATION INSTRUCTIONS

244 Bergen Boulevard, Woodland Park, NJ 07424, Phone: 973.785.4347 - Fax: 973.785.4207

## BOX INSTALLATION - STEP 1

LOCATE AND POSITION BOX IN ACCORDANCE WITH FLOOR PLANS. TOP SURFACE OF TEMPORARY COVER **MUST** BE SET TO MATCH THE HEIGHT OF THE FINISHED FLOOR - i.e. STONE, WOOD OR CONCRETE - SEE TYPICAL INSTALLATION HEIGHTS. LEVEL AND ANCHOR BOX AS REQUIRED. USE SCREWS, NAILS, OR WIRE TO PREVENT BOX FROM FLOATING DURING POUR. REMOVE AND RETAIN TEMPORARY COVER AND SCREWS. ROUTE CONDUITS TO BOX AS REQUIRED. **GANG BRACKET SCREWS MUST BE IN PLACE AND BOTTOMED TO ENSURE SCREW VOIDS AFTER POUR.** PLACE THIS INSTALLATION GUIDE BACK INTO BOX, ALONG WITH ALL SUPPLIED ITEMS, AND REINSTALL TEMPORARY COVER.

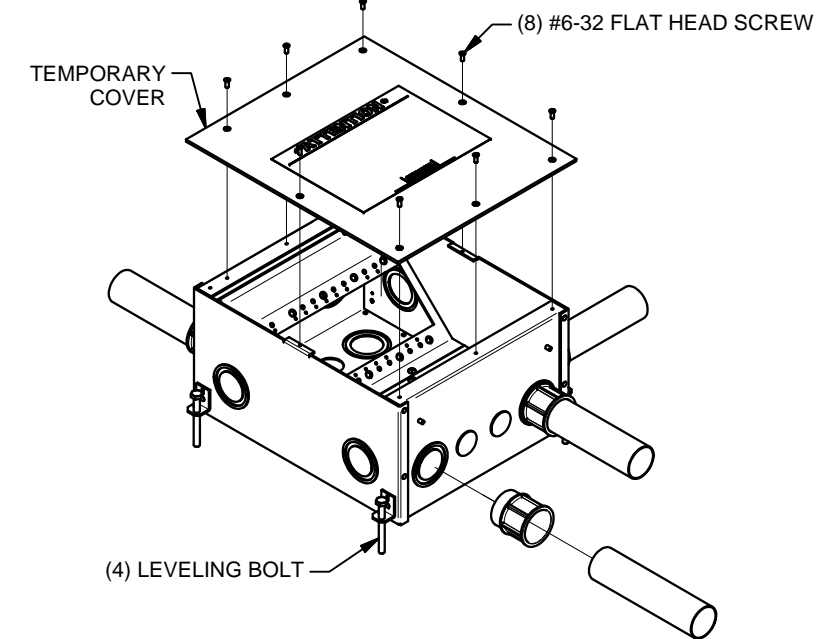

## BOX INSTALLATION - STEP 2

SCREED TO TOP OF BOX SURFACE FOR 3/16" THICK CARPET/FLOORING OR SPECIFIC HEIGHT TO ALLOW FOR THICKER FINISHED FLOOR MATERIAL. HAND TROWELING RECOMMENDED NEAR BOX EDGES. BOX HAS **NO** HEIGHT ADJUSTMENT AFTER CONCRETE POUR.

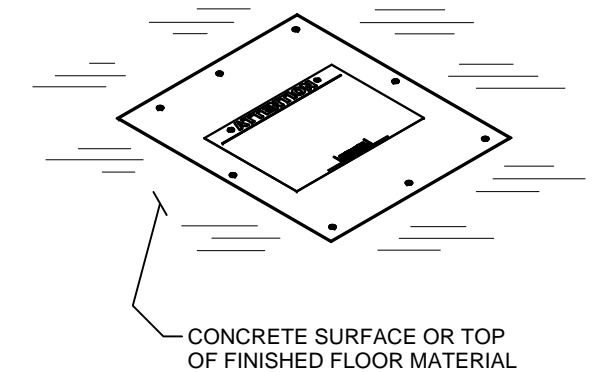

## TYPICAL INSTALLATION HEIGHTS

### CARPET OVER CONCRETE (COVER WITH BEVELED EDGING)

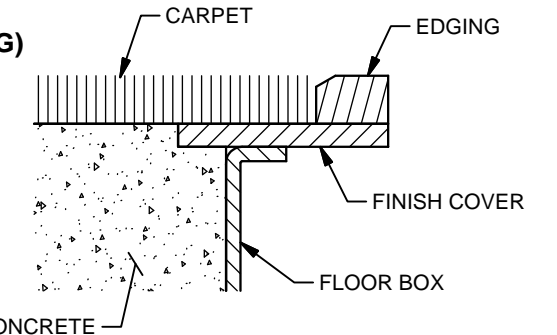
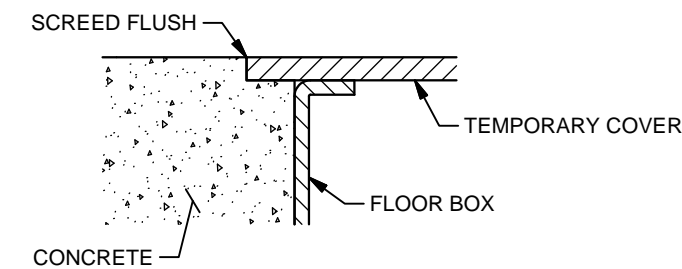

### TILE OR THIN WOOD LAMINATE OVER CONCRETE (COVER WITH SQUARE EDGING)

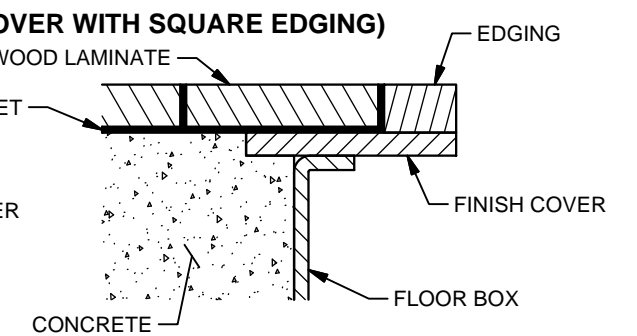
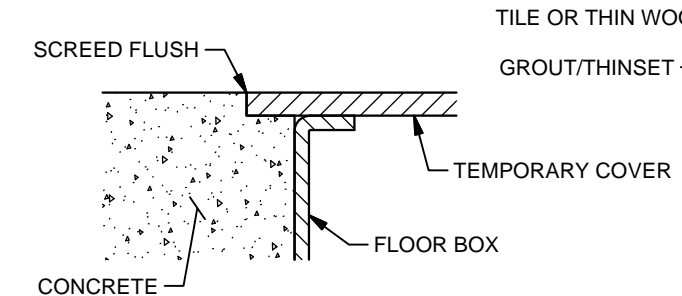

## TYPICAL INSTALLATION HEIGHTS

### WOOD WITH OR WITHOUT SLEEPER SYSTEM OVER CONCRETE (COVER WITH EDGING)

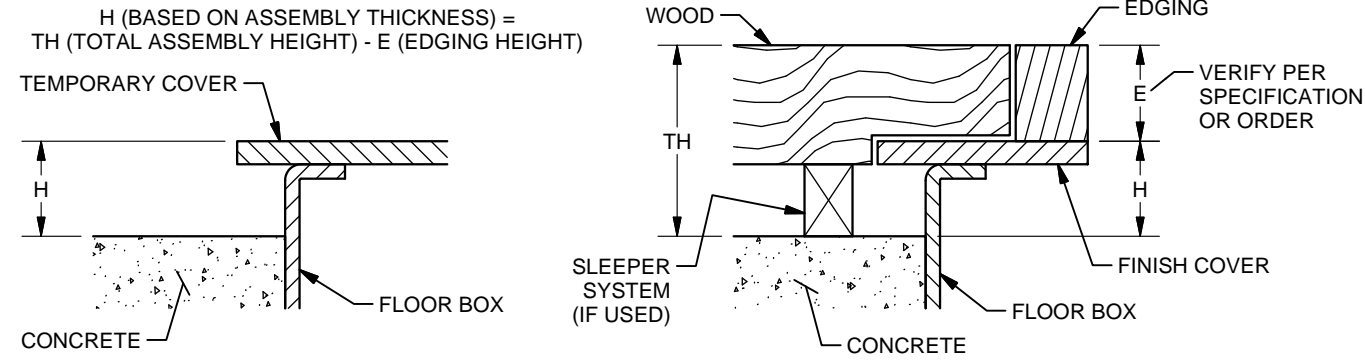

### WOOD WITH OR WITHOUT SLEEPER SYSTEM OVER CONCRETE (COVER WITHOUT EDGING)

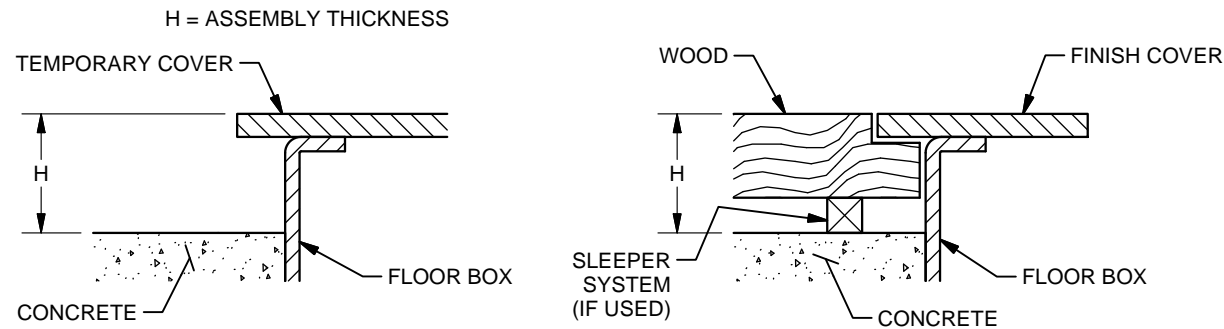

### VINYL FLOORING OVER CONCRETE (COVER WITHOUT EDGING)

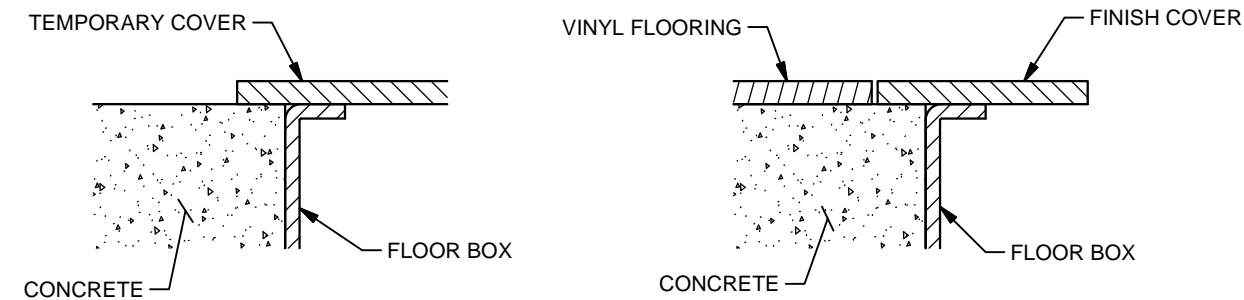

## CENTER DIVIDER CONFIGURATION (NOT APPLICABLE ON 4" BOX)

SET ASIDE TEMPORARY COVER AND SCREWS FOR POSSIBLE RE-INSTALLATION. REMOVE AND RETAIN GANG MOUNTING BRACKETS AND SCREWS TO CONFIGURE CENTER DIVIDERS.

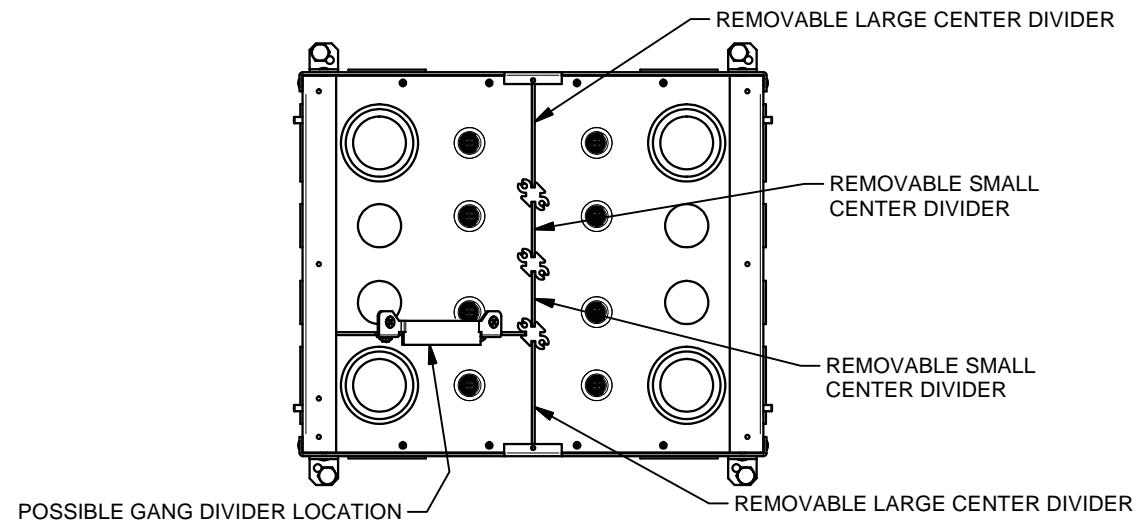

## GANG MOUNTING BRACKET CONFIGURATION

PER CUSTOMER SPECIFICATIONS, CONFIGURE GANG MOUNTING BRACKETS AS SHOWN BELOW AND REASSEMBLE INTO BOX (DECORA WALL PLATES SHOWN AS REFERENCE AND NOT INCLUDED).

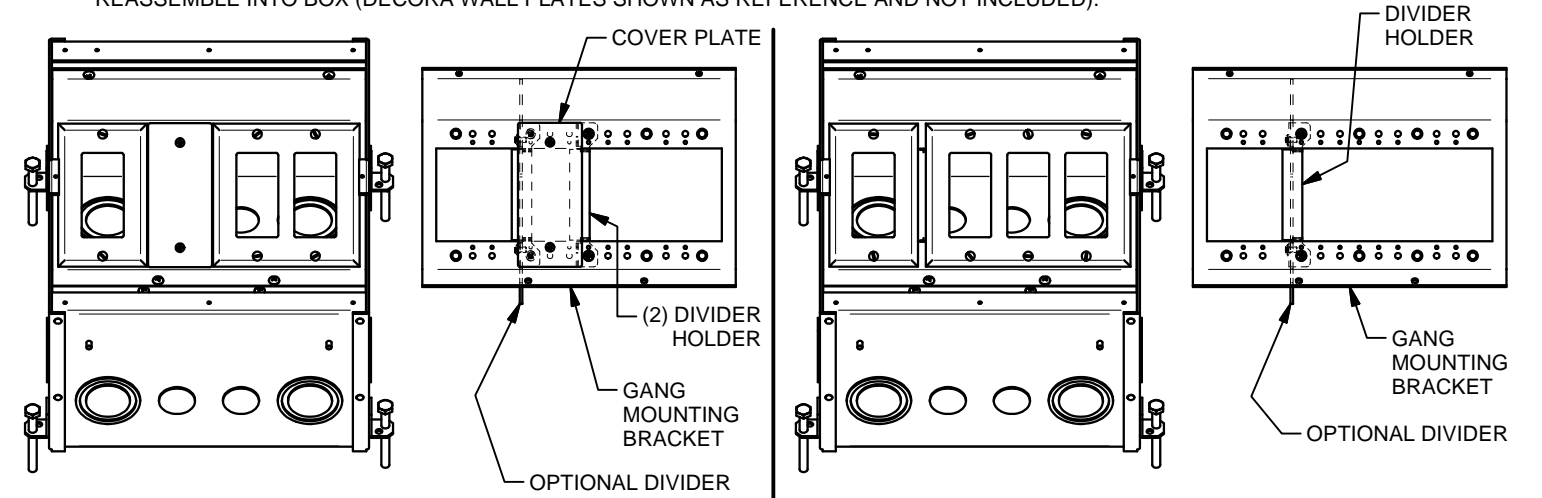

1-GANG/2-GANG CONFIGURATION

1-GANG/3-GANG CONFIGURATION

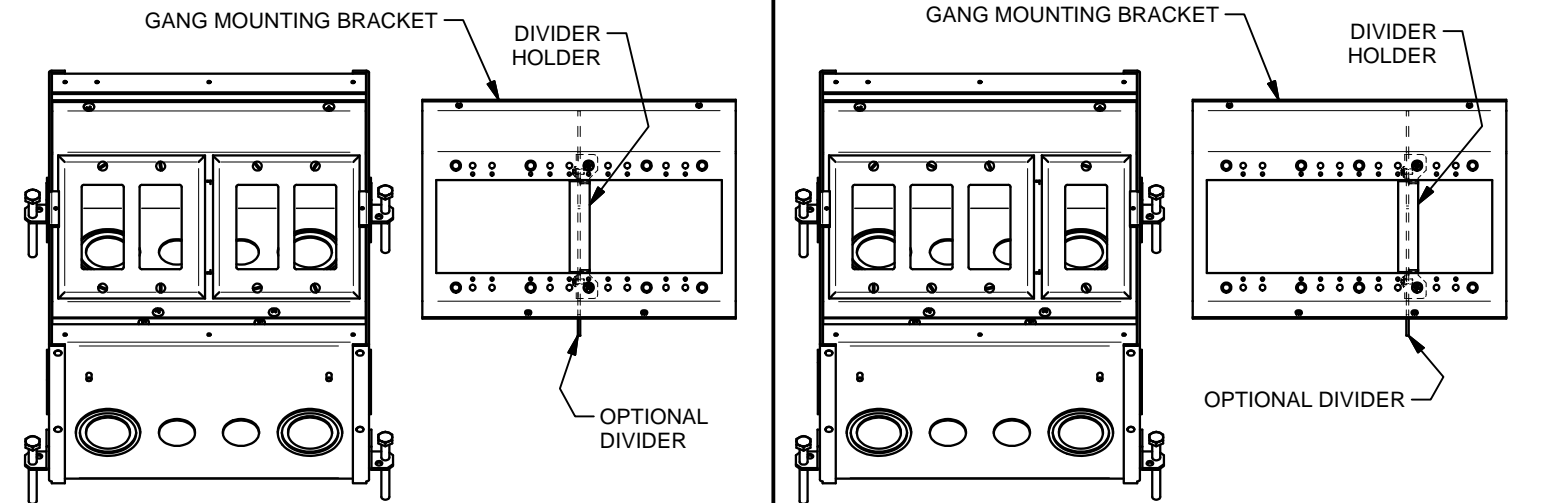

2-GANG/2-GANG CONFIGURATION

3-GANG/1-GANG CONFIGURATION

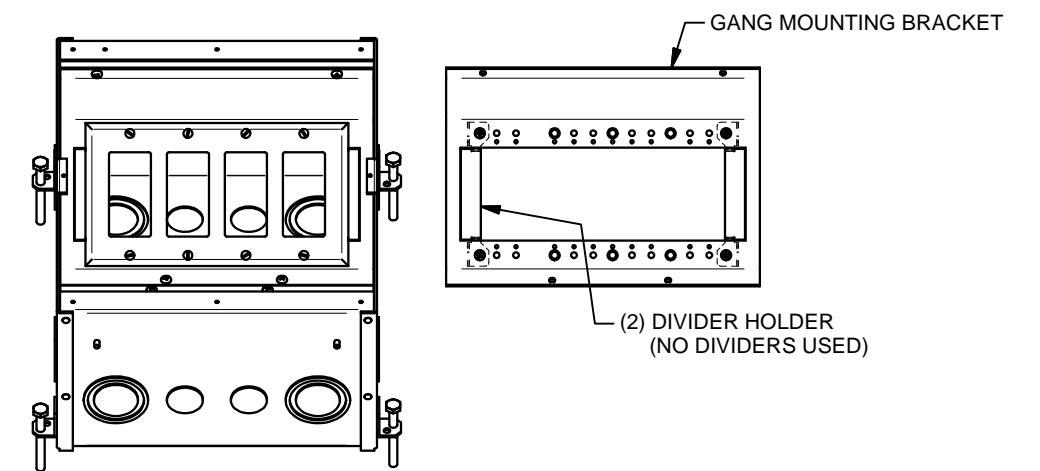

4-GANG CONFIGURATION

**BOTH GANG MOUNTING BRACKETS ARE IDENTICAL, AS IS THEIR CONFIGURATION CAPABILITY**